

KRW12DX-UC



1 NO contact potential free 16 A/250 V AC with tungsten pre-contact, max. inrush current 500 A/2 ms. No standby loss.

Modular device for DIN-EN 60715 TH35 rail mounting. 1 module = 18 mm wide, 58 mm deep. State-of-the-art hybrid technology combines advantages of nonwearing electronic control with high capacity of special relays.

With the patented Eltako Duplex technology (DX) the normally potential-free contacts can still switch in zero passage when switching 230 V AC 50 Hz and therefore drastically reduce wear. Simply connect the neutral conductor to the terminal (N) and L to 1(L) for this. This gives an standby consumption of only 0.1 watt.

If the contact is used for controlling switching devices which do not perform zero passage switching themselves, (N) should not be connected because the additional closing delay otherwise causes the opposite effect.

Universal control voltage 8 to 230 V UC.

Low switching noise.

Contact position indicator with LED.

By using a bistable relay coil power loss and heating is avoided even in the on mode.

The relay contact can be open or closed when putting into operation. It will be synchronised at first operation.

This relay is not suitable to feed back the switching voltage signal of a dimmer switch. Use only relays ESR12DDX-UC, ESR12NP-230V+UC or ESR61NP-230V+UC for this purpose.

The electronics does not have an internal power supply and therefore no standby loss.

The microcontroller is activated when the control contact closes. This switches the bistable relay to the correct direction. The bistable relay switches back either when the control contact opens or when the control voltage falls.

Typical connection

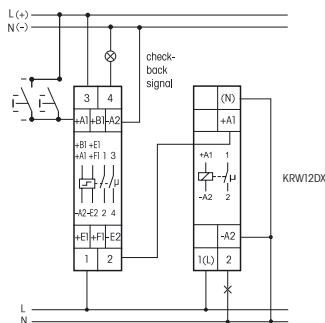

ES12Z with KRW12DX-UC

If N is connected, the zero passage switching is active.

Housing for operating instructions GBA14, see accessoires, chapter Z.

KRW12DX-UC	1 NO contact 16 A	EAN 4010312206683	44,00 €/pc.
-------------------	-------------------	-------------------	--------------------