

FSB71-2x-230V



Switch actuator for shading elements and roller shutters with 2 channels for two 230 V motors. 2+2 NO contact 4 A/250 V AC, not potential free. Encrypted wireless, bidirectional wireless and repeater function are switchable. Only 0.8 watt standby loss.

Mounting in the 230 V power supply cord, e.g. in false ceilings. 166 mm long, 46 mm wide and 31 mm high. With cable fixation.

Zero passage switching to protect contacts and motors.

A motor is connected to 1, 2 and N; a second motor may be connected to 3, 4 and N.

If supply voltage fails, the device is switched off in defined mode.

The pushbuttons can be taught-in either as direction pushbuttons or universal pushbuttons: Local control with universal pushbuttons: With each impulse the switch position changes in the sequence 'Up, stop, Down, Stop'.

Local control with direction pushbutton: A top impulse by pushbutton directly activates the 'UP' switch position. A bottom impulse by pushbutton directly activates the 'DOWN' switch position. A further impulse from one of the two pushbuttons stops the sequence immediately.

Central control dynamic without priority: A control signal from a pushbutton which was taught-in as a central control pushbutton without priority directly activates the switch position 'Up' with a scanning pulse up and the switch position 'Down' with a scanning pulse down. Without priority because this function can be overridden by other control signals. **Central control dynamic with priority:** A control signal of min. 2 seconds from a pushbutton which was taught-in as a central control pushbutton with priority directly activates the switch position 'Up' (press top) and the switch position 'Down' (press bottom). With priority because these control signals cannot be overridden by other (local) control signals until the central control signal is cancelled by pressing again the central control pushbutton 'Up' or 'Down'.

The switch position 'up' or 'down' and the priority are specifically activated with a control signal, e.g. from a FSM61 taught-in with priority as a central pushbutton. With priority because these control signals cannot be overridden by other control signals until the central command is cancelled by the termination of the control signal.

Shading scene control: Up to 4 already stored 'Down' runtimes can be called using the control signal of a pushbutton with double rocker taught-in as a scene pushbutton or automatically using an additional taught-in wireless exterior brightness sensor.

Shading scene control: Up to 4 already stored 'Down' runtimes can be called using the control signal of a pushbutton with double rocker taught-in as a scene pushbutton or automatically using an additional taught-in FAH60 wireless exterior brightness sensor.

When controlled via the GFVS software, Up and Down move commands can be started at the precise move time specified. Since the actuator reports back the precise time moved after each action, even when the movement is triggered by pushbutton, the position of the sunshading is always correctly displayed in the GFVS software. When the top or bottom end position is reached, the position is automatically synchronised.

Function rotary switch below: AUTO 1 = In this position, the local **advanced automatic reversing system for Venetian blinds** is activated. When a universal pushbutton or a direction pushbutton are used for control a double impulse activates a slow rotation in the opposite direction, which can be stopped with a further impulse. **AUTO 2 =** In this position, the local advanced automatic reversing system for Venetian blinds is completely switched off. **AUTO 3 =** In this position, the local pushbuttons act static at first, thus, allow reversal of Venetian blinds by operating pushbuttons. They only switch to dynamic after 0.7 seconds continuous operation. **AUTO 4 =** In this position, the local pushbuttons act only static (ER function). The time delay RV (wiping time) of the upper rotary switch is active. Central control is not possible. ▲▼ = ▲ (UP) and ▼ (DOWN) of the lower rotary switch are the positions for manual control. Manual control has priority over all other control commands. **WA = Automatic reversal** for Venetian blinds and awnings is controlled by the middle rotary switch. 0 = OFF, otherwise from 0.3 to 5 seconds ON with the selected reversal time. In this case, it is only for DOWN that the direction is reversed on time-out of the time lag selected by the top rotary switch, e.g. to extend awnings or set Venetian blinds to a defined position. A LED is located behind the RV-rotary switch to show the reversal time. **RV = The time delay** (delay time RV) is set by the top rotary switch. If the FSB is in the UP or DOWN position the selected delay time runs (elapses); at time-out the device changes automatically to STOP. Therefore, the time delay must be chosen at least as long as the shading element or roller shutter will need to move from one limit position to the other. The LED indication for the delay time RV is located behind the rotary switch RV.

When one or several wireless window/door contacts FTK or window handle sensors FFG7B-rw are taught-in, a lock-out protection is set up while the door is open which prevents Central down and Scene down.

The LED below the upper function rotary switch performs during the teach-in process according to the operating instructions. It shows control commands by short flickering during operation.

Function rotary switches

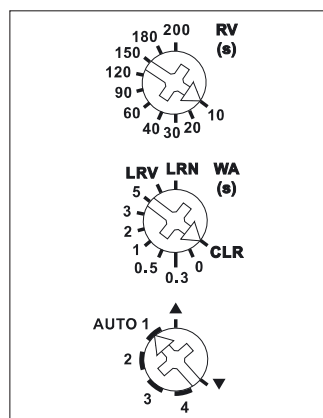

Standard setting ex works.

Further settings can be made and actuators configured using the PC Tool PCT14 and the data transformer DAT71.

FSB71-2x-230V	Wireless actuator for shading elements and roller shutters	EAN 4010312316290	112,70 €/pc.
----------------------	--	-------------------	---------------------