



21 100 800 - 4

1-10 V control dimmer switch SDS12/1-10V for electronic ballast units

Only skilled electricians may install this electrical equipment otherwise there is the risk of fire or electric shock!

Temperature at mounting location: -20°C up to +50°C.
Storage temperature: -25°C up to +70°C.
Relative humidity: annual average value <75%.

valid for devices from production week 21/22 (see bottom side of housing)

1 NO contact not potential free 600 VA and 1-10 V control output 40 mA. Only 0.5 watt standby loss. With adjustable minimum brightness and dimming speed. With switching operation for children's rooms and snooze function.

Modular device for DIN-EN 60715 TH35 rail mounting. 1 module = 18 mm wide, 58 mm deep. **Zero passage switching with soft ON and soft OFF to protect lamps.**

Also adapted for LED driver with 1-10V passive interface, without voltage source up to 0.6 mA, above this value an additional voltage source is necessary.

Universal control voltage 8 to 230 V UC, local and central on/off with same potential. Supply voltage 230 V electrically isolated.

State-of-the-art hybrid technology combines advantages of nonwearing electronic control with high capacity of special relays.

The brightness level is stored on switch-off (memory).

In case of a power failure the switch position and the brightness stage are stored and may be switched on when the power supply is restored.

Function rotary switches

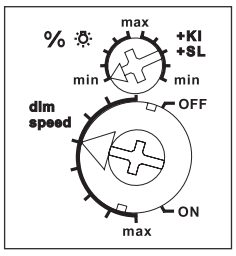

The minimum brightness (fully dimmed) is adjustable with the % rotary switch.

At the same time, you define whether the children's room function and the snooze function are active (+KI +SL).

The dimming speed is adjustable **using the dimming speed rotary switch.**

The load is switched on and off by a bistable relay at output EVG (electronic ballast units). Switching capacity for fluorescent lamps or LV halogen lamps with electronic ballast units 600VA.

By using a bistable relay coil power loss and heating is avoided even in the on mode.

After installation, wait for short automatic synchronisation before the switched consumer is connected to the mains.

Either direction switches can be connected to ▲▼ or these terminals are bridged and a pushbutton is connected as universal switch.

As a direction switch ▲ is 'switch on and dim up' and ▼ is 'switch off and dim down'. A double click at ▲ triggers the automatic updimming until full brightness with dim speed. A double click at ▼ triggers the snooze function. The children's room function is realized with the pushbutton at ▲.

As a universal switch, change the direction by briefly releasing the pushbutton.

Switching operation for children's rooms KI (universal switch or direction switch ▲): If the light is switched on by holding down the pushbutton, it starts at the lowest brightness level after approx. 1 second and dims up slowly as long as the pushbutton is held down without modifying the last stored brightness level.

Snooze function SL (universal switch or direction switch ▼): With a double impulse the lighting is dimmed down from the current dimming position to the minimum brightness

level and switched off. The current dimming position as well as the adjustable minimum brightness level determine the dimming time (max.= 60 minutes) which can be reduced as required. It can be switched off at any time by short-time control commands during the lighting is dimmed down. Holding down the pushbutton during the dimming down process dims up and stops the snooze function.

Typical connection with direction switch

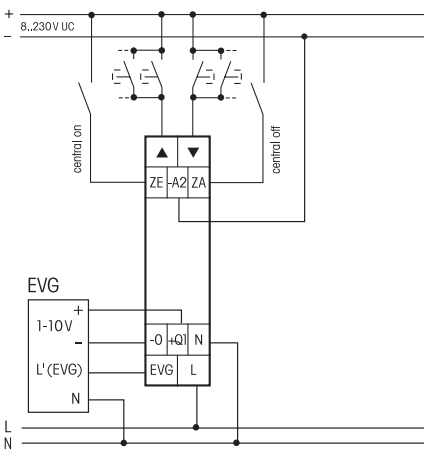

Typical connection with universal switch

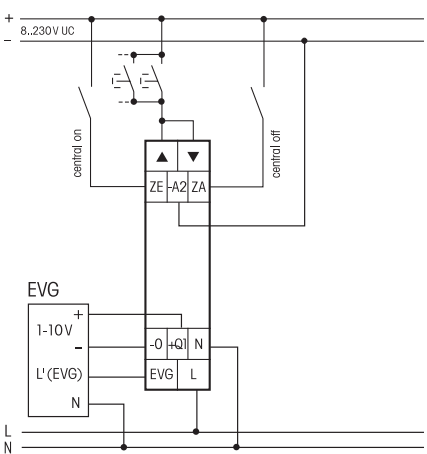

At more than 2 devices side by side, an half pitch must stay free for ventilation. For the control from several LED drivers with 1-10 V passive interface, an additional voltage source is necessary, this can be the power supply unit SNT12-230V/12V DC-1A or SNT61-230V/12V DC-0.5A, in both cases a 1kOhm resistor is necessary.

Example of connecting with an additional voltage source

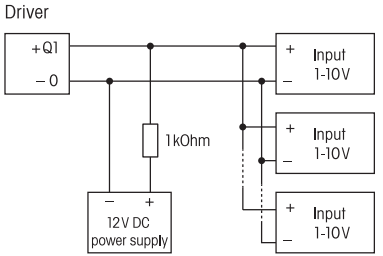

The strain relief clamps of the terminals must be closed, that means the screws must be tightened for testing the function of the device. The terminals are open ex works.

Manuals and documents in further languages



http://eltako.com/redirect/SDS12*1-10V



Must be kept for later use!

We recommend the housing for operating instructions GBA14.

Eltako GmbH
D-70736 Fellbach
Technical Support English:
☎ +49 711 94350025
✉ technical-support@eltako.de
eltako.com

18/2023 Subject to change without notice.