

RS485 bus actuator CE

Time relay for card switch or smoke alarm FZK14

Only skilled electricians may install this electrical equipment otherwise there is the risk of fire or electric shock!

Temperature at mounting location: -20°C up to +50°C.
Storage temperature: -25°C up to +70°C.
Relative humidity: annual average value <75%.

Time relay for card switch or smoke alarm, 1 NO contact potential free 16A/250V AC, incandescent lamps up to 2000 watts. Off-delay and response lag are adjustable. Bidirectional. Only 0.1 watt standby loss.

Modular device for DIN-EN 60715 TH35 rail mounting. 1 module = 18 mm wide, 58 mm deep.

Connection to the Eltako-RS485 bus. Bus cross wiring and power supply with jumper.

Patented Eltako Duplex technology allows you to switch normally potential free contacts in zero passage switching when 230V A/C voltage 50Hz is switched. This drastically reduces wear. To achieve this, simply connect the N conductor to the terminal (N) and L to 1(L). This results in an additional standby consumption of only 0.1 watt.

N may not be connected if a contactor is switched downstream for the purpose of increasing performance.

Function rotary switches

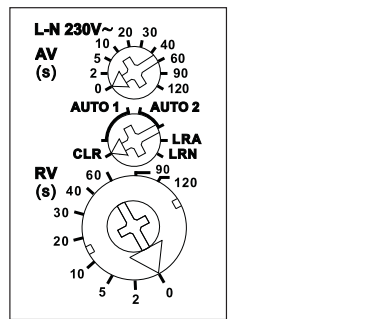

The upper rotary switch AV is required for teach-in. Then set here the response lag time AV between 0 and 120 seconds for contact.

The middle rotary switch is required for teach-in. Then the device response after a power failure is defined here. In AUTO1 position the switching state is retained when power is restored; in AUTO2 position, the device is switched off in a defined mode.

Use the bottom rotary switch RV to set the time delay time RV between 0 and 120 seconds for contact.

The AV and RV times permit the simple control of lights and air conditioning systems with the wireless card switches FKF and FKC.

The response lag AV starts as soon as the hotel card/key card is inserted in the wireless card-operated door lock FKF and the time delay RV starts after the card is removed.

In addition to the wireless card switch FKF, wireless window/door contacts FTK, Hoppe window handles and motion/brightness sensor FBH can also be taught in.

Opening a monitored window also starts the RV time. When the RV time expires, contact opens. Closing all monitored windows starts the AV time. When the AV time expires, contact closes.

When motion/brightness sensors are used and the hotel card/key card is inserted, contact closes immediately motion is detected. If no motion is detected for 15 minutes the contact opens, even if the hotel card/key card is inserted.

Several wireless smoke alarms FRW-ws are logically linked with this switch actuator time relay so that the RV time only starts after all FRW-ws devices have signalled alarm end.

Card switches and smoke alarms can not be operated together with an FZK device.

The LED below the upper function rotary switch performs during the teach-in process according to the operation manual. It shows control commands by short flickering during operation.

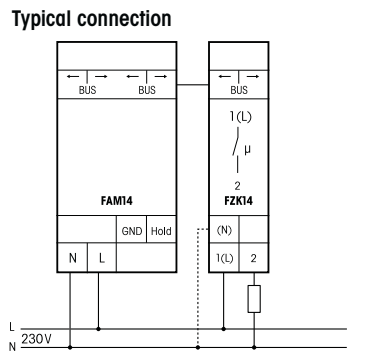

Teaching-in wireless sensors in wireless actuators

All sensors must be taught-in in the actuators so that they can detect and execute commands.

Teaching-in actuator FZK14

The teach-in memory is empty on delivery from the factory. If you are unsure whether the teach-in memory contains something or not, you must first clear the memory contents completely:

Set the middle rotary switch to CLR. The LED flashes at a high rate. Within the next 10 seconds, turn the upper rotary switch three times to the right stop (turn clockwise) and then turn back away from the stop. The LED stops flashing and goes out after 2 seconds. All taught-in sensors are cleared.

Clear individual taught-in sensors in the same way as in the teach-in procedure, except that you set the middle rotary switch to CLR instead of LRN, and operate the sensor. The LED previously flashing at a high rate goes out.

- Teaching-in sensors**
1. Set the middle rotary switch to LRN. The LED flashes at a low rate.
 2. Operate the sensor to be taught-in. The LED goes out.

If more sensors require teach-in, turn the upper rotary switch briefly away from the LRN position and then back again.

After teaching-in with the top rotary switch set the response lag AV. Function dependent on sensor type:

Wireless card switch FKF:
After the hotel card/key card is inserted, the AV starts. At the end of the AV, the contact closes.

Wireless window/door contact FTK and/or Hoppe window handles:

After a window is closed, the AV starts. At the end of the AV, the contact closes.

Motion detector/brightness sensor FBH:
If 'motion' is sent, the contact closes immediately.

Use the middle rotary switch to set the function AUTO1 or AUTO2:

AUTO1: The relay switch position remains unchanged in case of a power failure.

AUTO2: The relay switches off in a defined state after a power failure.

Use the bottom rotary switch to set the time delay RV. Function dependent on sensor type:

Wireless card switch FKF:
After the hotel card/key card is removed, the RV starts. At the end of the RV, the contact opens.

Wireless window/door contact FTK and/or Hoppe window handles:
After a window is opened, the RV starts. At the end of the RV, the contact opens.

Motion detector/brightness sensor FBH:
If 'no motion' is sent, a fixed time delay of 15 minutes starts. At the end of the time delay, the contact opens.

Assign device address for the FZK14:

The rotary switch on the FAM14 is set to position 1, its lower LED flashes red. The middle rotary switch of the FZK14 is set to LRN, the LED flashes smoothly. After the address of the FAM14 was assigned, its lower LED flashes green for 5 seconds and the LED of the FZK14 goes out.

Delete device configuration:

Set the middle rotary switch to CLR. The LED flashes nervously. Then turn the upper rotary switch within 10 seconds 3 times to the leftmost stop (anticlockwise) and turn it back again. The LED stops flashing and goes out after 5 seconds. The factory settings are restored.

Delete device configuration and device address:

Set the middle rotary switch to CLR. The LED flashes nervously. Then turn the upper rotary switch within 10 seconds 6 times

to the leftmost stop (anticlockwise) and turn it back again. The LED stops flashing and goes out after 5 seconds. The factory settings are restored and the device address deleted.

Configure FZK14:
The following points can be configured with the PC tool:

- teaching-in of wireless pushbuttons with single or double click
- add or change sensors

CAUTION! Don't forget 'disconnect FAM' in the PC tool. While the connection from the PC tool to the FAM14 exists, no wireless commands are executed.



When an actuator is ready for teach-in (the LED flashes at a low rate), the very next incoming signal is taught-in. Therefore, make absolutely sure that you do not activate any other sensors during the teach-in phase.

Must be kept for later use!
We recommend the housing for operating instructions GBA14.

Eltako GmbH
D-70736 Fellbach
+49 711 94350000
www.eltako.com