

RS485 bus actuator



4-channel impulse switch

FSR14-4x

**Only skilled electricians may install this electrical equipment otherwise there is the risk of fire or electric shock!**

Temperature at mounting location:

-20°C up to +50°C.

Storage temperature: -25°C up to +70°C.

Relative humidity:

annual average value &lt;75%.

4-channel impulse switch with integrated relay function, 1 NO contact per channel 4A/250V AC, incandescent lamps

1000 watts, potential free from the power supply, with DX technology. Bidirectional. Only 0.1 watt standby loss.

Modular device for DIN-EN 60715 TH35 rail mounting. 1 module = 18 mm wide, 58 mm deep.

**Connection to the Eltako-RS485 bus. Bus cross wiring and power supply with jumper.**

**Patented Eltako Duplex technology allows you to switch normally potential free contacts in zero passage switching when 230V A/C voltage 50Hz is switched.**

**This drastically reduces wear. To achieve this, simply connect the N conductor to the terminal (N) and L to K(L).**

**This results in an additional standby consumption of only 0.1 watt.**

When all 4 relays of the FSR14-4x are switched on, a power of 0.7 watts is required.

If supply voltage fails, the device is switched off in defined mode.

## Function rotary switches

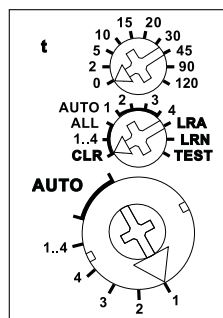

**The channels can be taught-in as ES and/or ER channel separately from each other.**

### Scene control:

Several channels of one or several FSR14-4x devices can be switched on or off in a scene by one of the four signals of a pushbutton with double rocker taught-in as a scene button.

**Central commands on PC** are sent using the FVS Wireless Visualisation and Control Software. To do this, teach-in one or several FSR14-4x devices.

**Use the rotary switches** to teach-in the buttons and test the 4 channels as required. For normal mode, the middle and lower rotary switches are then set to AUTO. With the upper rotary switch the EW time (0-120 seconds) is directly set for relays or the RV time (0-120 minutes) for impulse switches for all channels if necessary.

**When wireless motion detector and brightness sensors FBH** are taught-in, define the switching threshold separately for each channel using the top rotary switch. The switching threshold switches the lighting on or off depending on the brightness (also motion) (from approx. 30 lux in position 0 to approx. 300 lux in position 90). If the FBH is taught-in in position 120, it is only evaluated as a motion detector. A off delay of 1 minutes is a fixed setting in the FBH. An additionally set RV time is not taken into account.

**When wireless brightness sensors FAH60** are taught-in, define the switching threshold separately for each channel using the top rotary switch. The switching threshold switches the lighting on or off depending on the brightness (from approx. 0 lux in position 0 to approx. 50 lux in position 120). A hysteresis of approx. 300 lux is permanently set for switch on/off. An additionally set RV time is not taken into account.

Only one FBH or FAH is taught-in per channel. However, one FBH or FAH can be taught-in in several channels.

**When wireless window/door contacts FTK oder Hoppe window handles** are taught-in, different functions can be set with the middle rotary switch in position AUTO 1 to AUTO 4 and linked to maximum 116 FTKs:

AUTO 1 = window closed then output active.

AUTO 2 = window open then output active.

In settings AUTO 3 and AUTO 4 the FTKs taught-in to a single channel are linked automatically. With AUTO 3 all FTKs must be closed so that the N/O contact closes (e.g. for climate control). With AUTO 4 one open FTK is sufficient to close the N/O contact (e.g. for an alarm signal or to switch on the power supply for an extractor hood).

One or several FTKs can be taught-in in several channels to allow several simultaneous functions in each FTK.

After a power failure the link is restored by a new signal to the FTK and a signal on the next status message 15 minutes later. An additionally set RV time is not taken into account.

**The LED** below the upper function rotary switch performs during the teach-in process according to the operation manual. It shows control commands by short flickering during operation.

### Technical data

Rated switching capacity 4A/250V AC each contact

Incandescent lamp and 1000W  
halogen lamp load<sup>1)</sup> 230V

Fluorescent lamp load with KVG\*  
500 VA  
in lead-lag circuit or non compensated

Fluorescent lamp load with KVG\* 250 VA  
shunt-compensated or with EVG\*<sup>2)</sup>

Compact fluorescent lamps with EVG\*  
8x7W  
and energy saving lamps 5x20W

Standby loss (active power) 0.1W

<sup>1)</sup> Applies to lamps of max. 150W.

<sup>2)</sup> I on ≤ 10A

\* EVG = electronic ballast units;  
KVG = conventional ballast units

## Typical connection

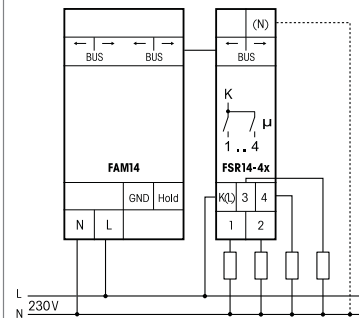

### Teaching-in wireless sensors in wireless actuators

**All sensors must be taught-in in the actuators so that they can detect and execute commands.**

### Teaching-in actuator FSR14-4x

The teach-in memory is empty on delivery from the factory. If you are unsure whether the teach-in memory contains something or not, **you must first clear the memory contents completely:**

Set the middle rotary switch to CLR ALL (or to CLR 1..4 if you only want to clear one channel and also set the lower rotary switch to the required channel). The LED flashes at a high rate. Within the next 10 seconds, turn the upper rotary switch three times to the right stop (turn clockwise) and then turn back away from the stop. The LED stops flashing and goes out after 2 seconds. All taught-in sensors or sensors of a channel are cleared.

**Clear individual taught-in sensors** in the same way as in the teach-in procedure, except that you set the middle rotary switch to CLR instead of LRN, and operate the sensor. The LED previously flashing at a high rate goes out.

### Teaching-in sensors

- Select the required Channel 1 to 4 or 1..4 using the lower rotary switch.
- Use the upper rotary switch to select the required teach-in function.  
0 = teach in 'direction button';  
Rocker is completely taught-in automatically when operating the pushbutton.

The side on which the pushbutton is first operated is defined for switching on, the other side for switching off.

5 = teach in 'universal button ES';

10 = teach in 'universal button ER';

15 = teach in 'central control button ON' with priority;

20 = teach in 'central control button OFF' with priority;

Central buttons have priority as long as they are pressed.

30 = teach in 'scene button';

Scene buttons (double rocker) are taught-in in fully automatic mode.

'Save scenes' as described further on.

45 = teach in 'central control button ON';

90 = teach in 'central control button OFF';

3. Set the middle rotary switch to LRN. The LED flashes at a low rate 1.

4. Press the sensor to be taught-in. The LED goes out.

The position of the upper rotary switch is unimportant for FTK and PC during the teach-in process.

To teach-in further sensors, turn the middle rotary switch briefly away from position LRN. Continue the procedure from pos 1.

A pushbutton (rocker end) can only execute the same last taught-in function of different channels of a FSR14-4x. Different pushbuttons can execute different functions of one or more channels of a FSR14-4x.

**After teaching-in**, set the middle and lower rotary switches to AUTO and turn the upper function rotary switch to the required time. For taught-in window/door contacts FTK, note that the middle rotary switch must be in the required setting AUTO 1 to 4.

#### Teach in scenes

Up to 4 scenes are being saved with a previously taught-in scene pushbutton.

1. All 4 channels of the impulse switch can be turned on or off individually with a previously taught-in universal-, direction-, or central pushbutton as it is desired for one scene.

2. The switch state is saved within 60 seconds when you press one of the four rocker ends of the doublerocker scene button for longer than 3 seconds but shorter than 10 seconds.

3. If more scenes have to be saved return back to point 1.

#### Recall scenes:

Press one rocker of the scene pushbutton briefly to recall the scene you require.

An additionally set RV time is not taken into account.

#### When the middle rotary switch is set to TEST,

the 4 contacts can be closed individually using the lower rotary switch:

TEST + AUTO = all contacts open,

TEST + 1 = contact 1 closed,

TEST + 2 = contact 2 closed,

TEST + 3 = contact 3 closed,

TEST + 4 = contact 4 closed,

TEST + 1..4 = all contacts closed.

#### Assign device address for the FSR14:

The rotary switch on the FAM14 is set to position 1, its lower LED flashes red. The lower rotary switch of the FSR14 is set to 1..4. The middle rotary switch of the FSR14 is set to LRN, the LED flashes smoothly. After the address of the FAM14 was assigned, its lower LED flashes green for 5 seconds and the LED of the FSR14 goes out.

#### Delete device configuration:

Set the middle rotary switch to ALL.

The LED flashes nervously. Then turn the upper rotary switch within 10 seconds 3 times to the leftmost stop (anticlockwise) and turn it back again. The LED stops flashing and goes out after 5 seconds. The factory settings are restored.

#### Delete device configuration and device address:

Set the middle rotary switch to ALL.

The LED flashes nervously. Then turn the upper rotary switch within 10 seconds 6 times to the leftmost stop (anticlockwise) and turn it back again. The LED stops flashing and goes out after 5 seconds. The factory settings are restored and the device address deleted.

#### Configure FSR14:

The following points can be configured with the PC tool:

- behavior upon return of supply voltage
- teaching-in of wireless pushbuttons and wireless Hoppe window handles with single or double click
- scenes for scene pushbuttons
- add or change sensors

**CAUTION! Don't forget 'disconnect FAM' in the PC tool. While the connection from the PC tool to the FAM14 exists, no wireless commands are executed.**

#### Teach-in confirmation telegram of another bus actuator to the FSR14:

As in the teach-in procedure, only set the middle rotary switch to LRA instead to LRN. Teach-in 'switch ON' as 'central control button ON'. Teach-in 'switch OFF' as 'central control button OFF'.



When an actuator is ready for teach-in (the LED flashes at a low rate), the very next incoming signal is taught-in. Therefore, make absolutely sure that you do not activate any other sensors during the teach-in phase.

#### Must be kept for later use!

We recommend the housing for operating instructions GBA14.

#### Eltako GmbH

D-70736 Fellbach

+49 711 94350000

www.eltako.com

03/2013 Subject to change without notice.