

RS485 bus switching actuator CE for shading elements and roller shutters FSB12-12V DC

valid for devices from production week 39/10
(see bottom side of housing)

2-channel switching actuator for two 230V motors, impulse group switch for central control 2+2 NO contact 4A/250V AC, potential free from power supply 12V. Only 0.1 watt standby loss.

Modular device for DIN-EN 60715 TH35 rail mounting. 1 module = 18mm wide, 58mm deep.

Connection to the Eltako RS485 Bus, terminals RSA and RSB. Up to a total of 128 actuators can be added in this way.

Up to 35 pushbuttons each with 4 functions can be maximal assigned to each channel, therefrom one or more central pushbuttons.

Zero passage switching to protect contacts and motors.

A motor is connected to 1, 2 and N; a second motor may be connected to 3, 4 and N.

The 12V DC supply voltage of the complete RS485 bus is mainly powered at 6W, 12W or 24W by a switch mode power supply unit SNT12-12V DC that is only 1 or 2 pitch units wide. If both relays of the FSB12 are switched on, a power of 0.5 watts is required.

The LED which is located behind the rotary switch RV performs during the teach-in process according to the operation manual and shows control commands by short flickering during operation.

The pushbuttons can be taught-in either as direction switches or universal switches:

Local control with universal pushbuttons: Each impulse causes the FSB12 to change its position in the UP-Stop-DOWN-Stop sequence.

Local control with direction pushbutton: A top impulse by pushbutton directly activates the 'UP' switch position. A bottom impulse by pushbutton directly activates the 'DOWN' switch position. A further impulse from one of the two pushbuttons stops the sequence immediately.

Central control dynamic without priority: A control signal from a pushbutton with rocker or double rocker which was taught-in as a central control direction pushbutton directly activates the switch position 'Up' with a scanning pulse

up and the switch position 'Down' with a scanning pulse down. A further control signal interrupts this process immediately. Without priority because this function can be overridden by other control signals.

Central control dynamic with priority: A control signal of min. 2 seconds from a pushbutton which was taught-in as a central control pushbutton with priority directly activates the switch position 'Up' (press top) and the switch position 'Down' (press bottom). With priority because these control signals cannot be overridden by other (local) control signals **until** the central control signal is cancelled by pressing again the central control pushbutton 'Up' or 'Down'.

Shading scene control:

Up to 4 saved 'Down' running times are retrievable using the control signal of a pushbutton and double rocker taught-in as a **scene pushbutton** or taught-in by a PC loaded with the FVS software. If this was not the last function of the two channels anyway, the shutter is moved until the end of the RV delay time for 'Up' set in the top rotary switch to ensure a safe starting position. The device then switches over automatically to 'Down' and stops on expiry of the saved time. If a turning time is set for blinds, this is used to turn the blinds. If FTKs are taught-in, they do not hinder shading scene control. The scene pushbutton can be taught-in for Channel 1 (Motor 1) or Channel 2 (Motor 2) or identically for both channels. If a **wireless outdoor brightness sensor FAH60** is also taught-in in addition to a scene pushbutton, the taught-in scenes 1, 2 and 4 are executed automatically depending on the outdoor brightness: Scene 1 in direct sunlight (>25 KLux), Scene 2 in daylight (300 Lux to 25 KLux) and Scene 4 in darkness (<50 Lux). During the first teach-in, therefore, a scene pushbutton is assigned automatically to Scenes 1 = no function, 2 = raise fully and 4 = lower fully. Scene 1 must be taught-in separately if the FAH60 is to trigger a shading system when direct sunlight is detected. A taught-in Scene 3 is only retrievable by means of a scene pushbutton.

Scenes 2 and 4 can be changed separately at any time. However, this is not advisable if the right rocker is programmed to be used as a normal up/down shutter pushbutton or an FAH60 was taught-in.

FAH60 wireless telegrams for Scenes 1 = direct sunlight are executed immediately and 4 = darkness.

Three telegrams are required for Scene 2 = daylight in order to mask out interference lights. To prevent 'nervous' opening and closing of a shading element when there is rapid fluctuation between darkness and brightness, changing FAH60 wireless telegrams are only executed every 2 minutes.

The automatic systems can be cancelled or overridden at any time by confirming any one of the taught-in pushbuttons. Central pushbuttons always have priority.

Function rotary switches

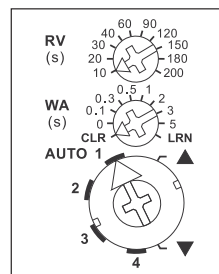

Function rotary switch below

AUTO 1 = In this position, the **local advanced automatic reversing system for Venetian blinds** is activated. When a universal pushbutton or a direction pushbutton are used for control a double impulse activates a slow rotation in the opposite direction, which can be stopped with a further impulse.

AUTO 2 = In this position, the local advanced automatic reversing system for Venetian blinds is completely switched off.

AUTO 3 = In this position, the local pushbuttons act static at first, thus, allow **reversal of Venetian blinds** by operating pushbuttons.

They only switch to dynamic after 0.7 seconds continuous operation.

AUTO 4 = In this position, the local pushbuttons act only static (ER function). The time delay RV (wiping time) of the upper rotary switch is active. Central control is not possible.

▲▼ = ▲ (UP) and ▼ (DOWN) of the lower rotary switch are the positions for **manual**

control. Manual control has priority over all other control commands.

WA = Automatic reversal for Venetian blinds and awnings is controlled by the middle rotary switch. 0 = OFF, otherwise from 0.1 to 5 seconds ON with the selected reversal time. In this case, it is only for DOWN that the direction is reversed on time-out of the time lag selected by the top rotary switch, e.g. to extend awnings or set Venetian blinds to a defined position. A LED is located behind the RV-rotary switch to show the reversal time.

RV = The time delay (delay time RV) is set by the top rotary switch. If the FSB12 is in the UP or DOWN position the selected delay time runs (elapses); at time-out the device changes automatically to STOP. Therefore, the time delay must be chosen at least as long as the shading element or roller shutter will need to move from one limit position to the other. The LED indication for the delay time RV is located behind the rotary switch RV.

When one or several wireless window/door contacts FTK or Hoppe window handles are taught-in, a lock-out protection is set up while the door is open and disables a Central Down command.

Typical connection

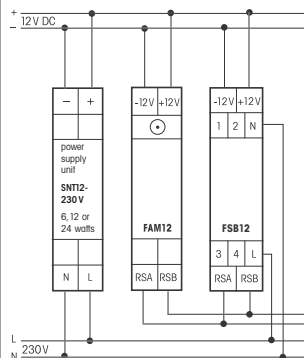

Teaching-in wireless sensors in wireless actuators

All sensors such as wireless pushbuttons, wireless hand-held transmitters, wireless transmitter modules, wireless window/door contacts, wireless timers and wireless motion/brightness sensors must be taught-in in the actuators (receivers with dimmers, switches and relays) so that they can detect and execute commands.

Teaching-in actuator FSB12-12V DC

The teach-in memory is empty on delivery from the factory. If you are unsure whether the teach-in memory contains something or not, **you must first clear the memory contents completely:**

Set the middle rotary switch to CLR. The LED flashes at a high rate. Within the next 10 seconds, turn the upper rotary switch three times to the right stop (turn clockwise) and then turn back away from the stop. The LED stops flashing and goes out after 2 seconds. All taught-in sensors are cleared.

Clear individual taught-in sensors in the same way as in the teach-in procedure, except that you set the middle rotary switch to CLR instead of LRN, and operate the sensor. The LED previously flashing at a high rate goes out.

Teaching-in sensors

- Set the top rotary switch to the required teach-in function:
 - 10 = direction switch motor 1;
 - 20 = universal switch and window/door contact FTK motor 1;
 - 30 = direction switch motor 2;
 - 40 = universal switch and window/door contact FTK motor 2;
 - 60 = central control pushbutton motors 1 and 2 without priority;
 - 90 = central control pushbutton motors 1 and 2 with priority; the first short-time control command switches on the priority, the second one switches it off.
 - 120 = central control switch motors 1 and 2 with priority, the priority remains switched on as long as the switch is closed.

- 150 = FAH60 Motor 1 and Motor 2
 - 180 = scene pushbutton and PC Motor 1
 - 200 = scene pushbutton and PC Motor 2
- Set the middle rotary switch to LRN. The LED flashes at a low rate.

- Operate the sensor to be taught-in. The LED goes out. Central control unit pushbuttons are completely taught-in automatically: central OFF is up (O) and central ON is down (I) on the pushbutton. As central control unit pushbutton either a rocker or the right half of a double rocker can be taught-in. With other pushbuttons, teach-in the upper and lower buttons as required. Scene pushbuttons (double rocker) are taught-in in fully automatic mode. Before operation, the scenes are saved there, if required individually, as described below.

To teach-in further sensors, turn the middle rotary switch briefly away from position LRN. Continue the procedure from pos 1.

After teaching-in, set the off delay RV, the reversal time WA (possibly 0) and AUTO 1, 2, 3 or 4.

Teaching-in shading scenes:

The following scenes are saved in scene pushbuttons that are taught-in in fully automatic mode, as described above. 1 = No function; 2 = Raise fully; 3 = No function, and 4 = Lower fully. Scenes 1 and 3 may have to be taught-in separately. Scenes 2 and 4 may also be changed separately. However, this is not advisable if the right-hand rocker is programmed to be used as a normal up/down shutter pushbutton or an FAH60 was taught-in.

Individual teach-in: Start 'Down' from the top end position with an already taught-in universal or direction switch. The point of time of repressing the pushbutton then determines the function which can then be taught-in in the scene pushbutton:

- a) Press the pushbutton immediately to cancel another function that is saved.
- b) Press the pushbutton after approx. 1s to trigger the standard function 'Up'.
- c) Press the pushbutton after more than 2 s, but shorter than the RV time setting to trigger the function 'Stop after this time' for shading purposes.
- d) Do not press pushbutton any more and wait until the RV time has expired. This triggers the standard function 'Down'.

The teach-in the scene pushbutton: Press the required double rocker end for approx. 3s but not longer than 5s. Then open the shading element fully by pressing the universal or direction switch and continue as described above for other scenes.



When an actuator is ready for teach-in (the LED flashes at a low rate), the very next incoming signal is taught-in. Therefore, make absolutely sure that you do not activate any other sensors during the teach-in phase.

Important Note!

Only skilled electricians may install this electrical equipment otherwise there is the risk of fire or electric shock.