

## RS485 bus switching actuator

### for shading elements and roller shutters FSB12-12V DC

valid for devices from production week 34/09  
(see bottom side of housing)

2-channel switching actuator for two 230V motors, impulse group switch for central control 2+2 NO contact 4A/250V AC, potential free from power supply 12V. Only 0.1 watt standby loss.

Modular device for DIN-EN 60715 TH35 rail mounting. 1 module = 18mm wide, 58mm deep.

**Connection to the Eltako RS485 Bus, terminals RSA and RSB. Up to a total of 128 channels can be added in this way.**

Up to 35 pushbuttons each with 4 functions can be maximal assigned to each channel, therefrom one ore more central pushbuttons.

**Zero passage switching** to protect contacts and motors.

A motor is connected to 1, 2 and N; a second motor may be connected to 3, 4 and N.

When both relays are switched on, 0.5 watts are required.

The LED which is located behind the rotary switch RV performs during the teach-in process according to the operation manual and shows control commands by short flickering during operation.

**The pushbuttons can be taught-in either as direction switches or universal switches:**

**Local control with universal pushbuttons:** Each impulse causes the FSB12 to change its position in the UP-Stop-DOWN-Stop sequence.

**Local control with direction pushbutton:** A top impulse by pushbutton directly activates the 'UP' switch position. A bottom impulse by pushbutton directly activates the 'DOWN' switch position. A further impulse from one of the two pushbuttons stops the sequence immediately.

**Central control dynamic without priority:** A control signal from a pushbutton with rocker or double rocker which was taught-in as a central control direction pushbutton directly activates the switch position 'Up' with a scanning pulse up and the switch position 'Down' with a scanning pulse down. A further control signal interrupts this process immediately. Without priority because this function can be overridden by other control signals.

**Central control dynamic with priority:** A control signal of min. 2 seconds from a pushbutton which was taught-in as a central control pushbutton with priority directly activates the switch position 'Up' with a scanning pulse up and the switch position 'Down' with a scanning pulse down. With priority because these control signals cannot be overridden by other control signals until an impulse is cancelled by pressing pushbutton 'Up' or 'Down' before pressing the central control pushbutton.

### Function rotary switches

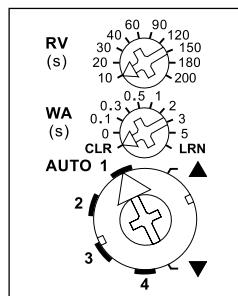

#### Function rotary switch below

**AUTO 1 =** In this position, the local advanced automatic reversing system for Venetian blinds is activated. When a universal pushbutton or a direction pushbutton are used for control a double impulse activates a slow rotation in the opposite direction, which can be stopped with a further impulse.

**AUTO 2 =** In this position, the local advanced automatic reversing system for Venetian blinds is completely switched off.

**AUTO 3 =** In this position, the local pushbuttons act static at first, thus, allow reversal of Venetian blinds by operating pushbuttons. They only switch to dynamic after 0.7 seconds continuous operation.

**AUTO 4 =** In this position, the local pushbuttons act only static (ER function). The time delay RV (wiping time) of the upper rotary switch is active. Central control is not possible.

▲▼ = ▲ (UP) and ▼ (DOWN) of the lower rotary switch are the positions for manual control. Manual control has priority over all other control commands.

**WA = Automatic reversal** for Venetian blinds and awnings is controlled by the middle rotary switch. 0 = OFF, otherwise from 0.1 to 5 seconds ON with the selected reversal time. In this case, it is only for DOWN that the direction is reversed on time-out of the time lag selected by the top rotary switch, e.g. to extend awnings or set Venetian blinds to a defined position. A LED is located behind the RV-rotary switch to show the reversal time.

**RV = The time delay** (delay time RV) is set by the top rotary switch. If the FSB12 is in the UP or DOWN position the selected delay time runs (elapses); at time-out the device changes automatically to STOP. Therefore, the time delay must be chosen of least as long as the shading element or roller shutter will need to move from one limit position to the other. The LED indication for the delay time RV is located behind the rotary switch RV.

**When one or several wireless window/door contacts FTK or Hoppe window handles are taught-in,** a lock-out protection is set up while the door is open and disables a Central Down command.

### Typical connection

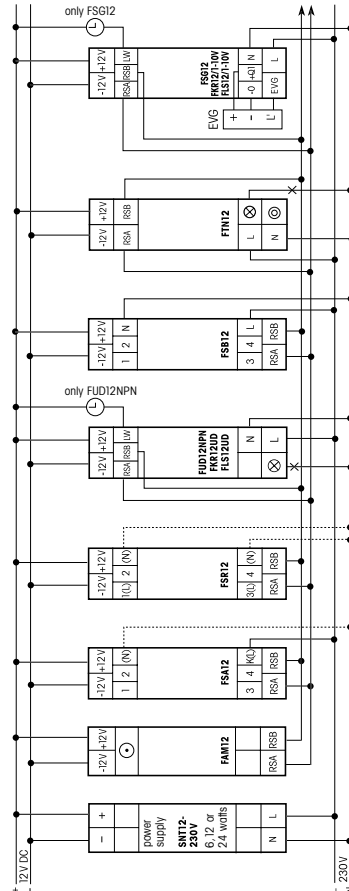

#### Technical data

Rated switching capacity each contact	4A/250V AC
Incandescent lamp and halogen lamp load <sup>1)</sup> 230V	up to 1000W
Fluorescent lamp load with KVG* in lead-lag circuit or non compensated	500VA
Fluorescent lamp load with KVG* shunt-compensated or with EVG*	250VA
Compact fluorescent lamps with EVG* and energy saving lamps	8x7W 5x20W
Standby loss (active power)	0,1W

<sup>1)</sup> Applies to lamps of max. 150W.

\* EVG = electronic ballast units;  
KVG = conventional ballast units

#### Teaching-in wireless sensors in wireless actuators

All sensors such as wireless pushbuttons, wireless hand-held transmitters, wireless transmitter modules, wireless window/door contacts, wireless timers and wireless motion/brightness sensors must be taught-in in the actuators (receivers with dimmers, switches and relays) so that they can detect and execute commands.

#### Teaching-in actuator FSB12-12V DC

The teach-in memory is empty on delivery from the factory. If you are unsure whether the teach-in memory contains something or not, **you must first clear the memory contents completely:** Set the middle rotary switch to CLR. The LED flashes at a high rate. Within the next 10 seconds, turn the upper rotary switch three times to the right stop (turn clockwise) and then turn back away from the stop. The LED stops flashing and goes out after 2 seconds. All taught-in sensors are cleared.

**Clear individual taught-in sensors** in the same way as in the teach-in procedure, except that you set the middle rotary switch to CLR instead of LRN, and operate the sensor. The LED previously flashing at a high rate goes out.

#### Teaching-in sensors

- Set the top rotary switch to the required teach-in function:
  - 10 = direction switch motor 1;
  - 20 = universal switch and window/door contact FTK motor 1;
  - 30 = direction switch motor 2;
  - 40 = universal switch and window/door contact FTK motor 2;
  - 60 = central control pushbutton motors 1 and 2 without priority;
  - 90 = central control pushbutton motors 1 and 2 with priority;
 Positions 120 to 200 are not assigned.
- Set the middle rotary switch to LRN. The LED flashes at a low rate.
- Operate the sensor to be taught-in. The LED goes out. Central control unit pushbuttons are completely taught-in automatically: central OFF is up (O) and central ON is down (I) on the pushbutton. As central control unit pushbutton either a rocker or the right half of a double rocker can be taught-in. With other pushbuttons, teach-in the upper and lower buttons as required.

The base plate of the wireless window/door contact must be removed in order to conduct a teach-in. Press the red button to initiate a teach-in.

To teach-in further sensors, turn the middle rotary switch briefly away from position LRN. Continue the procedure from pos 1.

After teaching-in, set the off delay RV, the reversal time WA (possibly O) and AUTO 1, 2 or 3.



When an actuator is ready for teach-in (the LED flashes at a low rate), the very next incoming signal is taught-in. Therefore, make absolutely sure that you do not activate any other sensors during the teach-in phase.

**Important reminder!**  
This electrical equipment may only be installed by skilled electricians otherwise fire hazard or danger of electric shock exists!