

RS485 bus dimming actuator CE
1-10V light scene controller
FLS12/1-10V for electronic ballast units

Dimming actuator 1 channel, 1 NO contact not potential free 600VA and 1-10V control output 40mA. Only 0,9 watt standby loss. Stores up to 40 light scenes for a fluorescent lamp group with 1-10V ballasts.

Modular device for DIN-EN 60715 TH35 rail mounting.
1 module = 18mm wide, 58mm deep.

Zero passage switching to protect contacts.

In case of a power failure the switch position and the brightness stage are stored and may be switched on when the power supply is restored.

Connection to the Eltako RS485 Bus, terminals RSA and RSB. Up to a total of 128 channels can be added in this way.

By using a bistable relay coil power loss and heating is avoided even in the on mode.

After installation, wait for short automatic synchronisation before the switched consumer is connected to the mains.

Function of FLS12/1-10V

All FLS12's in a room can be switched in series to obtain light scenes. The brightness of each lamp group is manually adjustable and the entire light scene can then be taught-in. Up to 40 light scenes are programmable.

Up to 10 light scenes are retrievable sequentially with only one pushbutton.
Up to 30 additional light scenes are directly retrievable with single assigned pushbuttons.

Each FLS12 or FLS12 groups can also be switched and dimmed individually. There are a total of 35 inputs on each FLS12 for light scene and individual pushbuttons. Retrieving a light scene overrides an individual setting.

The same function as a light scene pushbutton has an associated taught-in wireless transmitter module FSM12 or FSM61. Specific light scenes can then be retrieved with event-dependent or time-dependent control.

Function rotary switches

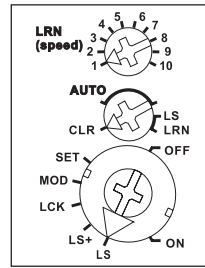

Typical connection various wireless actuators

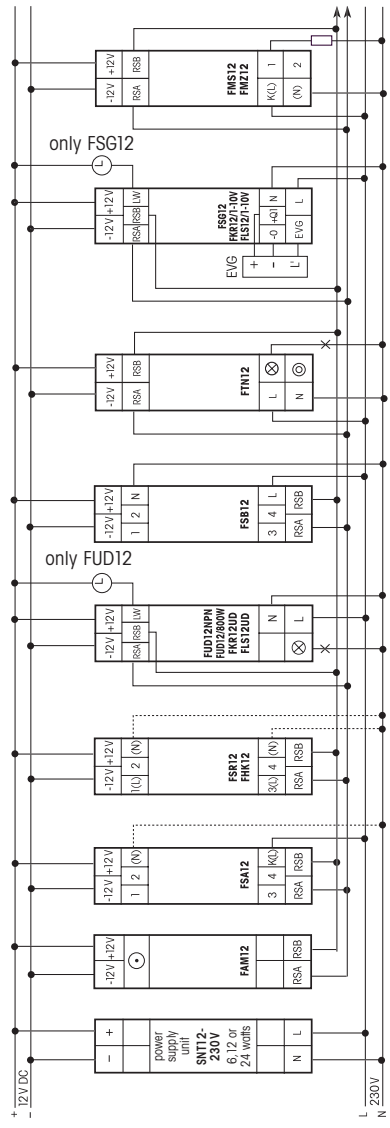

Teaching-in wireless sensors in wireless actuators

All sensors such as wireless pushbuttons, wireless hand-held transmitters, wireless transmitter modules, wireless window/door contacts, wireless timers and wireless motion/brightness sensors must be taught-in in the actuators (receivers with dimmers, switches and relays) so that they can detect and execute commands.

Teaching-in actuator FLS12

Also the mains connection N/L is required for teach-in.

The teach-in memory is empty on delivery from the factory. If you are unsure whether the teach-in memory contains something or not, you must first **clear the memory contents completely**:

Set the middle rotary switch to CLR. The LED flashes at a high rate. Within the next 10 seconds, turn the upper rotary switch three times to the right stop (turn clockwise) and then turn back away from the stop. The LED stops flashing and goes out after 2 seconds. All taught-in sensors are cleared.

Clear individual taught-in sensors in the same way as in the teach-in procedure, except that you set the middle rotary switch to CLR instead of LRN, and operate the sensor. The LED previously flashing at a high rate goes out.

Light scene teach-in is carried out after completion of the electrical installation.

Set the bottom rotary switch of all FLS12 to 'ON' or 'OFF' for function tests.

1. First a shared **direction switch is taught-in** for all FLS12's required to control the light scenes in a room. This is a FT4 wireless pushbutton rocker or a wireless FHS8 or FHS12 hand-held transmitter.

1a. Teaching-in the "learn pushbutton"

Here set the top learn ('LRN') rotary switch to position 5 and the middle rotary switch to 'LRN'. The LED on the FLS12 flashes at a low rate. Then briefly press the rocker at the top or bottom and the LED on the FLS goes out. From then on the required brightness stages can be adjusted for the light scenes using this "learn pushbutton".

1b. Teaching-in the sequential light scene pushbutton

Here set the top learn ('LRN') rotary switch to position 3 and the middle rotary switch

to 'LRN'. The LED on the FLS12 flashes at a low rate.

Then briefly press the rocker at the top or bottom and the LED on the FLS goes out. Using this just taught-in sequential light scene pushbutton the sequential light scene can be retrieved later. A double-click at the top will switch all the lamp groups to full brightness. The light scenes can then be called up again in ascending order (top switch) or descending order (bottom switch). Additional direct light scene retrieval functions cannot be assigned to the sequential light scene pushbutton.

2. Then set the bottom rotary switch to LOCK ('LCK') on all FLS12's.

3. Teaching-in the sequential retrievable light scenes

3a. Set the middle rotary switch to 'AUTO'.

3b. Set the bottom rotary switch to 'MOD'.

3c. Set the top rotary switch to the required light scene position (1 to 10).

3d. Adjust the required brightness, using the "learn pushbutton" taught-in at the beginning.

Even if the lamp group in a light scene needs to be switched off, it must be taught-in now by switching off the "learn pushbutton" at the bottom.

3e. Turn the bottom rotary switch to 'SET', the LED on the FLS lights up and goes out after 2 seconds.

To store further light scenes continue with step 3b.

4. Teaching-in the directly retrievable light scenes

4a. Set the bottom rotary switch to 'LS+'.

4b. Use the upper rotary switch to set the required dim speed.

1 = very slow to 10 = very fast.

We advise you to select position 5 unless you have your own experiences.

4c. Set the middle rotary switch to 'AUTO'.

4d. Adjust the required brightness, using the "learn pushbutton" taught-in at the beginning.

Even if the lamp group in a light scene needs to be switched off, it must be taught-in now by switching off the "learn pushbutton" at the bottom.

4e. Set the middle rotary switch to 'LS', the LED flashes at a low rate.

4f. Operate the required light scene pushbutton and the LED on the FLS goes out.

To store further light scenes continue with step 4b.

Then for normal mode set the middle rotary switches to 'AUTO' and set all the top rotary switches to the same number of sequential light scenes which have been taught in.

The bottom rotary switch can be used to control the settings in automatic mode for each lamp group.

ON = light on with full brightness.

LS = light scenes are only retrievable and can not be changed.

LS+ = light scenes are retrievable and can only be changed temporarily using the "learn pushbutton".

OFF = light off.

If individual lamp groups can be influenced temporarily and manually, only an additional direction switch in each case need to be taught-in for one or more FLS12's as described in '1a'.

In total up to 4 pushbuttons can be taught-in for each FLS12 without reducing the 40 storage places of the light scenes. Accordingly if fewer light scenes are taught-in, more pushbuttons are available.

Teach-in **central control functions** in the same way as light scenes. When teaching-in 'Central OFF' all lamp groups must be in position 'switched off'. 'Central ON' needs to be taught-in at a required brightness level.

Brightness for emergency lighting: As long as the control input NB is connected to +12V DC, it is dimmed to the maximum brightness. All wireless signals are ignored then.

When an actuator is ready for teach-in (the LED flashes at a low rate), the very next incoming signal is taught-in. Therefore, make absolutely sure that you do not activate any other sensors during the teach-in phase.

Important reminder!

This electrical equipment may only be installed by skilled electricians otherwise fire hazard or danger of electric shock exists!