

RS485 bus actuator **CE**
Single room control, heating/cooling for
2 zones with solid state relay FAE14SSR

**Only skilled electricians may install
this electrical equipment otherwise
there is the risk of fire or electric
shock!**

Temperature at mounting location:
-20°C up to +50°C.
Storage temperature: -25°C up to +70°C.
Relative humidity:
annual average value <75%.

Noiseless 2-channel single room control,
400W. 2 solid state relays not potential
free. Bidirectional. Only 0.1 watt standby
loss.

Modular device for DIN-EN 60715 TH35
rail mounting. 1 module = 18mm wide,
58mm deep.

**Connection to the Eltako-RS485 bus.
Bus cross wiring and power supply with
jumper.**

If both relays are switched on, a power
of 0.4 watts is required.

**The rated switching capacity of 400W is
applied for one contact and also for the
sum of the two contacts.**

**First teach in the sensors using the rotary
switches.**

The channels can be taught-in together
at the same time. Use the lower rotary
switch in positions 1+2. Alternatively,
they can be taught-in separately in
position 1 or 2.

Function rotary switches

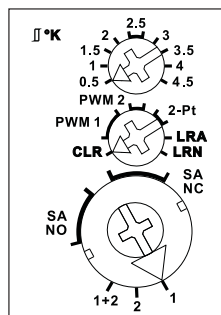

**Then set the operating mode using the
middle rotary switch:**

PWM 1 for valves with thermoelectric
actuator, T = 4 minutes.

PWM 2 for valves with motor-driven
actuator, T = 15 minutes.

2-Pt for 2-point control.

PWM control mode:

The upper rotary switch sets the required
temperature difference at which the device
is switched on at 100%.

When the actual temperature \geq reference
temperature, the device is switched off.

When the actual temperature \leq (reference
temperature - hysteresis), the device is
switched on at 100%.

When the actual temperature is between
(reference temperature - hysteresis) and
the reference temperature, the device is
switched on and off by a PWM in steps
of 10% depending on the temperature
difference.

The lower the temperature difference, the
shorter the switch-on time. As a result of
the settable of the 100% value, the PWM
can be adapted to the radiator size and
inertia. The signs are the opposite in
cooling mode.

In heating mode, the **frost protection
function** is always enabled. As soon as
the actual temperature drops below 8°C,
the temperature is controlled in the
selected operating mode to 8°C.

Two-point control mode:

The upper rotary switch sets the required
difference between the switch-on and
switch-off temperatures.

When the actual temperature \geq reference
temperature, the device is switched off.

When the actual temperature \leq (reference
temperature - hysteresis), the device is
switched on.

The signs are the opposite in cooling mode.

The type of connected actuators will be
selected with the **lower rotary switch**.

SANC for actuator NC (normally closed)
or **SANO** for actuator NO (normally open).

When **wireless window/door contacts
FTK or Hoppe window handles** are
taught-in, they are OR linked. If one or
more windows are open, the output
remains off. In heating mode, however,
the frost protection remains enabled.

When **motion detectors FBH** are taught-in,
they are AND linked. If all FBHs signal
'No motion', the device switches to
standby setback mode: In heating mode,
the reference temperature is set back by
2°; in cooling mode, it is raised by 2°.
As soon as a motion detector signals

movement again, the device is switched
to normal mode.

When the **FBHs and wireless pushbuttons**
are taught-in, the last telegram received
is always the one that is valid. An FBH
therefore switches off a setback mode
selected by means of the wireless push-
button when motion is detected.

When a **wireless pushbutton** is taught-in,
the 4 keys are assigned the following
functions:

Top right: Normal mode (can also be
enabled by timer with the function 'ON').
Bottom right: Night setback mode by 4°;
in cooling mode: increase by 4° (can
also be enabled by timer with the function
'OFF'). Top left: Standby setback mode
by 2°, in cooling mode, increase by 2°.
Bottom left: Off (in heating mode, frost
protection enabled; in cooling mode
permanent off).

If no telegram is received from the
temperature sensor for longer than
60 minutes, the device switches to **fault
mode**: At heating mode it will be switched
on and off every 2 minutes at PWM 1 or
every 7.5 minutes at PWM 2. Since no
other actual temperature is known, it is
not possible to switch to frost protection
here. In cooling function, the output re-
mains off. In both cases the LED on the
device flashes at a constant low rate.
When telegrams are received again,
control continues in the selected mode
and the LED goes out.

The LED below the upper function rotary
switch performs during the teach-in
process according to the operating
instructions. It shows control commands
by short flickering during operation.

Typical connection

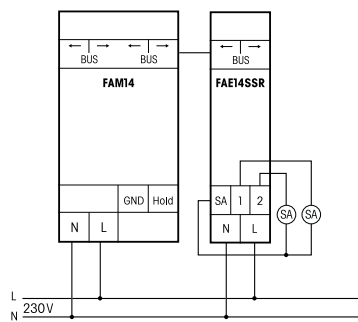

Teaching-in wireless sensors in wireless actuators

All sensors must be taught-in in the actuators so that they can detect and execute commands.

Teaching-in actuator FAE14SSR

The teach-in memory is empty on delivery from the factory. If you are unsure whether the teach-in memory contains something or not, **you must first clear the memory contents completely:**

Set the middle rotary switch to CLR and also the lower rotary switch to positions 1+2. The LED flashes at a high rate. Within the next 10 seconds, turn the upper rotary switch three times to the right stop (turn clockwise) and then turn back away from the stop. The LED stops flashing and goes out after 2 seconds. All taught-in sensors or sensors of a channel are cleared.

Clear individual taught-in sensors in the same way as in the teach-in procedure, except that you set the middle rotary switch to CLR instead of LRN, and operate the sensor. The LED previously flashing at a high rate goes out.

Teaching-in sensors (a total of 120 memory locations are available):

1. Set the top rotary switch to the required teach-in function.
Teach in at right stop (4.5):
FTR55D, FTR55H, FUTH55D, 4-way buttons FT4F, FT55 and FT4 as well as FBH, FTK and Hoppe window handle.
On FTF55, FAFT60, FIFT63 and FUTH55D, the position of the rotary switch defines the reference temperature during the teach-in process. In middle position (2.5) the reference temperature is 21°C. It can be set in steps of 1° from 17°C at left stop (0.5) to 25°C at right stop (4.5).
2. Set the lower rotary to positions 1+2, 1 or 2.
3. Set the middle rotary switch to LRN.
The LED flashes at a low rate.
4. Operate the sensor to be taught-in.
The LED goes out.

To prevent an accidental teach-in, turn the rotary switch back to LRN for further teach-in operations. The LED reverts to flashing at a low rate.

Assign device address for the FAE14:

For the basic units FME14 the addresses are already assigned ex works!

The rotary switch on the FAM14 is set to position 1, its lower LED flashes red. The lower rotary switch of the FAE14 is set to 1..2. The middle rotary switch of the FAE14 is set to LRN, the LED flashes smoothly. After the address of the FAM14 was assigned, its lower LED flashes green for 5 seconds and the LED of the FAE14 goes out.

Delete device configuration:

Set the middle rotary switch to CLR and the lower rotary switch to 1+2. The LED flashes nervously. Then turn the upper rotary switch within 10 seconds 3 times to the leftmost stop (anticlockwise) and turn it back again. The LED stops flashing and goes out after 5 seconds. The factory settings are restored.

Delete device configuration and device address:

Set the middle rotary switch to CLR and the lower rotary switch to 1+2. The LED flashes nervously. Then turn the upper rotary switch within 10 seconds 6 times to the leftmost stop (anticlockwise) and turn it back again. The LED stops flashing and goes out after 5 seconds. The factory settings are restored and the device address deleted.

Configure FAE14SSR additionally:

The following functions can be configured additionally using the PC Tool PCT14:

- Teach-in buttons and wireless Hoppe window handles using single and double clicks.
- Operating mode Channel 1 heating mode or cooling mode ('Heating mode' = factory setting)
- Operating mode Channel 2 heating mode or cooling mode ('Heating mode' = factory setting)
- Dewpoint evaluation Channel 1 ('enabled' = factory setting)
- Dewpoint evaluation Channel 2 ('enabled' = factory setting)
- Dewpoint without humidity values Channel 1 (15°C = factory setting)
- Dewpoint without humidity values Channel 2 (15°C = factory setting)
- Reference temperature for FAFT60, FTF, FUTH Channel 1 (21°C = factory setting)
- Reference temperature for FAFT60, FTF, FUTH Channel 2 (21°C = factory setting)
- Reference temperature for FTF55, FAFT60 and FIFT63
- Add or change sensors

Caution: If necessary do not forget to press 'Disconnect link to FAM' in the PC-Tool PCT14. While the PC Tool remains connected to the FAM14, no wireless commands can be executed.



When an actuator is ready for teach-in (the LED flashes at a low rate), the very next incoming signal is taught-in. Therefore, make absolutely sure that you do not activate any other sensors during the teach-in phase.

Must be kept for later use!

We recommend the housing for operating instructions GBA14.

Eltako GmbH

D-70736 Fellbach
☎ +49 711 94350000
www.eltako.com