

## Wireless sensor



## Outdoor twilight sensor with actuator FADS60-230V

### Wireless outdoor twilight sensor with actuator, 60x46 mm, 30 mm deep.

**1 NO contact not potential free 10A/250V AC, incandescent lamps 2000 Watt. Bidirectional wireless and with repeater function. Only 0.7 watt standby loss.**

This sensor/actuator combination can be used to switch on/off a garden lighting system, for example. In addition, wireless pushbuttons, hand-held wireless transmitters, FTK wireless window/door contacts and FABH63 wireless motion sensors can be taught in.

Every status change and incoming central control telegrams are confirmed by a wireless telegram. This wireless telegram can be taught into other actuators, the FVS-Software and FUA55 universal displays. Brightness parameters are not sent.

On the underside there is an M12 screw for the IP54 waterproof 230V mains connection. Connection to an internal 4-way terminal for L, 2 x N and the contact output. To access the terminal, undo the two screws on the front and remove the cover.

Also, there are two rotary switches inside to teach-in sensors and switch on/off the repeater function if required. In operation, these rotary switches are used to set the switching threshold 'ON in darkness' and 'OFF in brightness'. The switching threshold and hysteresis are selectable up to 200 lux.

**When the upper rotary switch is in ESV position, the twilight function is switched off and the actuator operates as an impulse switch. The lower rotary switch can be used to set a time delay.**

The LED performs during the teach-in process as mentioned in this instruction manual below. It shows wireless control commands by short flickering during operation.

### Twilight switch: (without FBH or FTK)

The upper rotary switch is used to set the switch-on threshold from 0 (left stop) to 200 lux (just before right stop). The lower rotary switch sets the switch-off threshold. Hysteresis is adjustable from 10 lux (left stop) to 200 lux (right stop). Switch-on takes place 60 seconds after the switch-on threshold is undershot. Switch-off takes place 60 seconds after the switch-off threshold is overshoot. If switches were already taught-in, the last switch

operation determines the switching state. Only when the next switching threshold is reached does the device return to automatic mode.



**When operated as a wireless motion/brightness sensor FBH acts as an NO contact and switches on in darkness and when motion is detected. The device switches off when 'no motion' or brightness is detected.**



If there are several FBH devices, switch-on takes place when at least one FBH detects motion. Switch-off takes place when all FBH devices report 'no motion' or brightness. When the FBH acts as an NC contact, it switches on when darkness and 'no motion' are detected and switches off when motion or brightness is detected.

When operated in combination with the **FTK wireless window/door contact**, it acts as an NO contact and switches on in darkness and 'window OPEN'. The device switches off when 'window CLOSED' or brightness is detected. In combination with several FTK devices, it switches on when a window is opened. It only switches off when all windows are closed or in brightness. When it acts as an NC contact, it switches on when darkness and 'window CLOSED' are detected and switches off when 'window OPEN' or brightness is detected.

### Function rotary switches

<b>Teaching-in</b>	upper rotary switch
3x LRN 5x Repeater	 3x CLR 5x CLRALL

<b>Twilight sensor</b>	upper rotary switch
Brightness setting	ON  200lux 0lux
	lower rotary switch
	OFF  200lux 10lux

<b>ESV mode</b>	upper rotary switch
Time setting	 200lux 0lux
	lower rotary switch
	 120min 2min

### Teaching-in actuator FADS60

The teach-in memory is empty on delivery from the factory. If you are unsure whether the teach-in memory contains something or not, **you must first clear the memory contents completely:**

Within the next 3 seconds, turn the upper rotary switch five times to the right stop (turn clockwise) and then turn back away from the stop. The LED lights up for 2 seconds. All taught-in sensors are cleared.

### Clearing individual taught-in sensors:

Within the next 3 seconds, turn the upper rotary switch three times to the right stop (turn clockwise) and then turn back away from the stop. The LED flashes at a high rate. Within the next 20 seconds operate the sensor. The LED goes out.

### Teaching-in sensors

- Setting of the lower rotary switch to the desired teaching-in function:  
**Left stop** = teach-in 'central OFF' and when FTK and FBH act as NC contacts;  
**Approx. middle** = teach-in 'ON/OFF';  
**Right stop** = teach-in 'central ON' and when FTK and FBH act as NO contact.
- Within the next 3 seconds, turn the upper rotary switch three times to the left stop (turn counter-clockwise) and then turn back away from the stop. The LED flashes at a low rate.
- Within the next 20 seconds operate the sensor. The LED goes out.

To teach-in further sensors, turn the upper rotary switch three times to the left stop and then turn back away from the stop. The LED flashes at a low rate again.

Either a FBH or a FTK can be taught in.

### Switching the repeater on and off

Turn the upper rotary switch five times to the left stop (turn counter-clockwise) and then turn back away from the stop. The LED lights up for 2 or 5 seconds. Then briefly switch off the power supply to activate or deactivate the repeater. The LED lights up for 2 seconds = repeater OFF (as-delivered state) or 5 seconds (repeater ON) to indicate the state when the power supply is applied.

### Teach-in confirmation telegrams of this actuator in other actuators:

At night 'switch-on' will be sent when supply voltage is applied.

At daytime 'switch-off' will be sent when supply voltage is applied.

### Typical connection

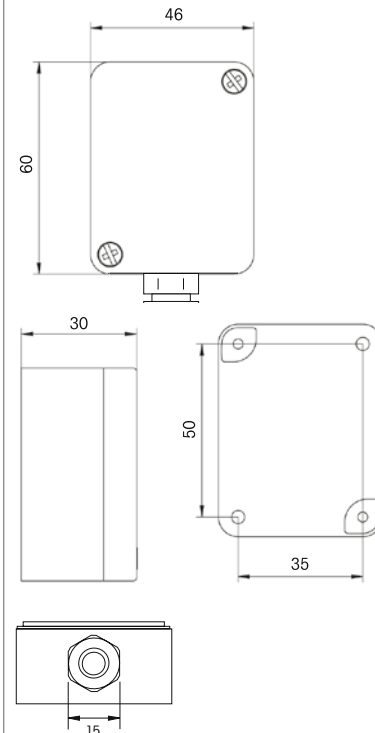
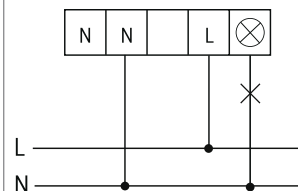

### Important note!

**Only skilled electricians may install this electrical equipment otherwise there is the risk of fire or electric shock.**