

RS485 bus actuator
2-speed fan relay F2L14



Only skilled electricians may install this electrical equipment otherwise there is the risk of fire or electric shock!

Temperature at mounting location:
-20°C up to +50°C.
Storage temperature: -25°C up to +70°C.
Relative humidity:
annual average value <75%.

valid for devices from production week 40/17 (see bottom side of housing)

2-speed fan relay, 1+1 NO contacts potential free 16A/250V AC, with DX technology. Bidirectional. Only 0.1 watt standby loss.
Modular device for DIN-EN 60715 TH35 rail mounting.
1 modul = 18mm wide, 58mm deep.

Connection to the Eltako-RS485 bus. Bus cross wiring and power supply with jumper.

Patented Eltako Duplex technology allows you to switch normally potential free contacts in zero passage switching when 230V A/C voltage 50Hz is switched. This drastically reduces wear. To achieve this, simply connect the N conductor to the terminal (N1) and L to 1(L) and/or N to (N2) and L to 3(L). This results in an additional standby consumption of only 0.1 watt.

If supply voltage fails, the switching state is retained. When supply voltage is restored, the device is switched off in defined mode.

This fan relay evaluates the information of up to 23 passive sensors, e.g. wireless pushbuttons, window/door contacts, Hoppe window handles or wireless transmitter modules. Active sensors for CO₂, humidity and temperature are also evaluated. Several active sensors can be linked by the PCT14 PC Tool.

When the two contacts are switched in parallel, the 2-speed actuator for 2 fan speeds becomes an actuator for one fan.

Function rotary switches

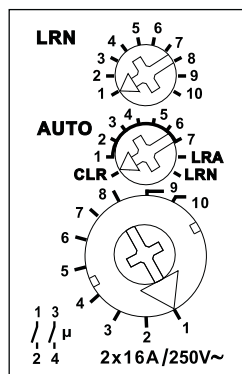

The middle rotary switch must be set to position LRN for teach-in. Set the required operating mode when the fan actuator is in operation.

During the teach-in process, adjust **the upper rotary switch** to set the sensor type. A wireless pushbutton (exclusive) with double rocker is taught-in in rotary switch position 1. Double rockers are assigned automatically: top left Stage 1 (only Contact 1-2 closed), top right Stage 2 (only Contact 3-4 closed). Bottom left and bottom right OFF: both contacts open.

A wireless pushbutton (**adding**) with double rocker is taught-in in rotary switch position 2. Double rockers are assigned automatically: top left Stage 1 (Contact 1-2 closed), top right Stage 2 (Contacts 1-2 and 3-4 closed). Bottom left and bottom right OFF: both contacts open. If you switch the two contacts in parallel, one wireless pushbutton and 1 rocker are sufficient. In this case, top is ON and bottom is OFF.

In rotary switch position 3, teach in ON/OFF switch with double rocker (all rockers are assigned automatically) and wireless transmitter modules. When you teach in an FTK device, Hoppe window handle or active sensor, there is no need to take the teach-in position into account.

When operated with an active sensor, set the switch-in threshold on **the lower rotary switch**. When the threshold is

reached, Stage 1 (Contact 1-2) is switched on. At **the upper rotary switch**, set the addition value at which Stage 2 (Contact 3-4). Turn **the middle rotary switch** to set one of the operating modes AUTO1 to AUTO7.

AUTO1 for manual mode of a 2-stage fan by means of a double rocker wireless pushbutton. Each contact is closed separately (exclusive) or contact 3-4 cuts in to switch stage 2 (accumulative). This is determined when teaching-in.

Passive sensors, such as wireless pushbuttons and transmitter modules, which are taught-in as a off-switches, cause opening of both contacts. As long as the control voltage is applied to transmitter modules or a window monitored by an FTK or Hoppe window handle is open, the contacts are open and can not be switched on manually.

AUTO2: Activating with wireless CO₂ sensor. The switch-on thresholds are set by the lower and upper rotary switches. The contacts close 'exclusively'.

AUTO3: Same as AUTO2, but activated by the wireless humidity sensor.

AUTO4: Same as AUTO2, but activated by the wireless temperature sensor.

AUTO5: Same as AUTO2, but the contacts close 'adding'.

AUTO6: Same as AUTO3, but the contacts close 'adding'.

AUTO7: Same as AUTO4, but the contacts close 'adding'.

Overview of switch-on thresholds (lower rotary switch):

CO₂ (ppm): 1 = 700ppm;
2 = 800ppm; 3 = 900ppm;
4 = 1000ppm; 5 = 1200ppm;
6 = 1400ppm; 7 = 1600ppm;
8 = 1800ppm, 9 = 2000ppm and
10 = 2200ppm.

Humidity (%): 1 = 10%, 2 = 20%,
... 10 = 100%.

Temperature (°C): 1 = 20°C, 2 = 22°C,
3 = 24°C, ... 10 = 38°C.

Overview of addition values (upper rotary switch):

CO₂ difference: 1 = 50ppm,
2 = 100ppm, 3 = 150ppm,
... 10 = 500ppm.

Fixed hysteresis: 50ppm.

Humidity difference: 1 = 5%, 2 = 10%,
3 = 15%, ... 10 = 50%.

Fixed hysteresis: 5%.

Temperature difference (K): 1 = 1K,
2 = 2K, 3 = 3K, ... 10 = 10K.

Fixed hysteresis: 1K.

The LED below the upper function rotary switch performs during the teach-in process according to the operating instructions. It shows control commands by short flickering during operation.

Typical connection

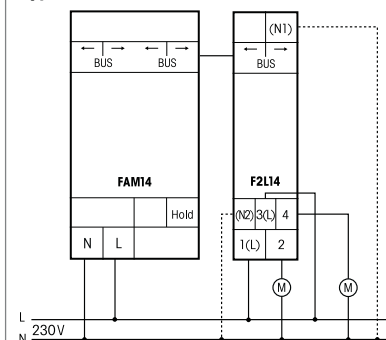

Teaching-in wireless sensors in wireless actuators

All sensors must be taught-in into the actuators so that they can detect and execute commands.

Teaching-in actuator F2L14

The teach-in memory is clear on delivery from the factory. To ensure that a device was not previously taught-in, **clear the complete memory:**

Turn the middle rotary switch to CLR. The LED flashes at a high rate. Within 10 seconds, turn the upper rotary switch three times to right stop (turn clockwise) and back again. The LED stops flashing and goes out after 2 seconds. All taught-in sensors are cleared.

Clear individual taught-in sensors in the same way as in the teach-in procedure, except that you set the middle rotary switch to CLR instead of LRN, and

operate the sensor. The LED previously flashing at a high rate goes out.

Teaching-in sensors:

1. Set the top rotary switch to the required teach-in function:

Pos. 1: Double pushbutton exclusive switching sequence.

Pos. 2: Double pushbutton adding switching sequence.

Pos. 3: OFF pushbutton.

You need not take a teach-in position into account for the following sensors:

FCO2TF65 (EEP: A5-09-04)

FTR65DS, FTR65HS (EEP: A5-10-06)

FTR78S (EEP: A5-10-03)

FTF65S (EEP: A5-02-05)

FIFT65, FAFT60 and FBH65TF

(EEP: A5-04-02)

FUTH65D (EEP: A5-10-06 and

EEP: A5-10-12)

FTK (EEP: D5-00-01), window handle

(EEP: A5-14-09, 0A), FTKE and

Hoppe window handle

2. Set the middle rotary switch to LRN.

The LED flashes at a low rate.

3. Press a sensor to teach it in. The LED stops flashing. To prevent unintentional teach-in, turn the rotary switch back to LRN for each teach-in process. The LED flashes at a slow rate.

To teach-in further sensors, turn the middle rotary switch briefly away from position LRN. Continue the procedure from pos 1.

After teach-in, set the rotary switches to the required function.

Issue device address for the F2L14:

Turn the rotary switch on the FAM14 to Pos. 1 and its lower LED lights up red.

Turn the middle rotary switch on the F2L14 to LRN and the LED flashes at a low rate. After the address of the FAM14 is issued, its lower LED lights up green for 5 seconds and the LED of the F2L14 goes out.

Clear device configuration:

Set the middle rotary switch to CLR. The LED flashes at a high rate. Within the next 10 seconds, turn the upper rotary switch three times to left stop (turn anticlockwise) and away again. The LED stops flashing and goes out after 5 seconds. The factory

settings are restored.

Clear device configuration and device address:

Set the middle rotary switch to CLR. The LED flashes at a high rate. Within the next 10 seconds, turn the upper rotary switch six times to left stop (turn anticlockwise) and away again. The LED stops flashing and goes out after 5 seconds. The factory settings are restored and the device address is cleared.

Configure F2L14:

The following points can be configured using the PC tool PCT14:

- Teach in buttons and wireless Hoppe window handles with single or double click
- Operating mode: depending on rotary switch position or PCT setting
- Evaluation: CO₂ and/or humidity and/or temperature
- Switch-in threshold for Stage 1
- Addition value for Stage 2
- Hysteresis
- Add or change sensors

Caution: Do not forget the 'Disconnect link to FAM' in the PC Tool. No wireless commands are executed while there is a link between the PC Tool PCT14 and the FAM14.



When an actuator is ready for teach-in (the LED flashes at a low rate), the very next incoming signal is taught-in. Therefore, make absolutely sure that you do not activate any other sensors during the teach-in phase.

Must be kept for later use!

We recommend the housing for operating instructions GBA14.

Eltako GmbH

D-70736 Fellbach

Technical Support English:

☎ Michael Thünte +49 176 13582514

✉ thunte@eltako.de

☎ Marc Peter +49 173 3180368

✉ marc.peter@eltako.de

eltako.com