



28 380 516 - 1



Modbus bidirectional three-phase meter DSZ15DZMOD-3x80A MID with display, MID calibrated

Only skilled electricians may install this electrical equipment otherwise there is the risk of fire or electric shock!

Temperature at mounting location: -20°C up to +50°C.
Storage temperature: -25°C up to +70°C.
Relative humidity: annual average value <75%.

Modbus bidirectional three-phase meter. Maximum current 3x80 A, standby loss only 0.8 watts at L1 and 0.5 W each at L2 and L3.

Modular installation device for mounting on mounting rail DIN-EN 60715 TH35 in installation cabinets with protection class IP51. 4 modules = 70 mm wide and 58 mm deep.
Accuracy class B (1%). With Modbus/ RTU (RS485) interface.

It measures active energy by means of the current between input and output. The internal power consumption of 0.8 resp. 0.5 watt active power per path is neither metered nor indicated.

The active energy is added depending on the sign. Positive power in the meter means energy consumption, negative power means energy delivery.

The energy measurement is balanced. If the energy consumption (P positive) is greater than the energy supply (P negative), the meter reading T → is increased. If the energy supply is greater than the energy consumption, the meter reading T ← is increased. Energy consumption is shown with a right arrow → and energy supply is shown with a left arrow ← above the active bar in the display.

1, 2 or 3 phase conductors with max. currents up to 80 A can be connected.
The inrush current is 40 mA.

L1 and N connections must be available.

Connection via RS485-Modbus data logger: Data transfer Modbus/RTU (RS485).
For the **last** meter in the RS485 bus, the enclosed terminating resistor (120 Ω) must be connected to the RSA/RSB terminals.

Energy consumption and energy supply values are stored in non-volatile memory and are displayed again immediately after a power failure.

The 7 segment LC display is also legible twice within a period of 2 weeks without power supply.

The power consumption and the power supply are indicated by an LED next to the display that flashes 1000 times per kWh..

On the right next to the display are the keys MODE and SELECT. Press them to scroll through the menu. First the **background lighting** switches on. Then the total active energy per consumption and delivery, the active energy of the resettable memory consumption and delivery as well as the instantaneous power, voltage and current values for each phase conductor can be displayed.

Error message

If a phase connection is missing, the corresponding phase is shown on the display.

Typical connection: 4-wire-connection 3x230/400 V

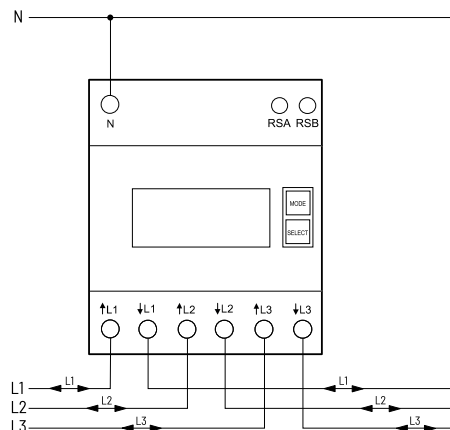

How it works

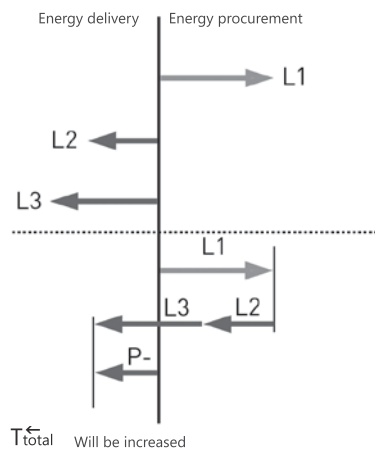
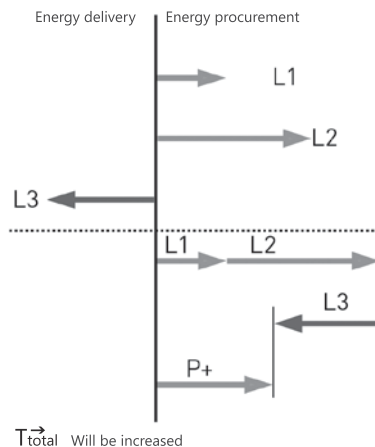

Menu guidance

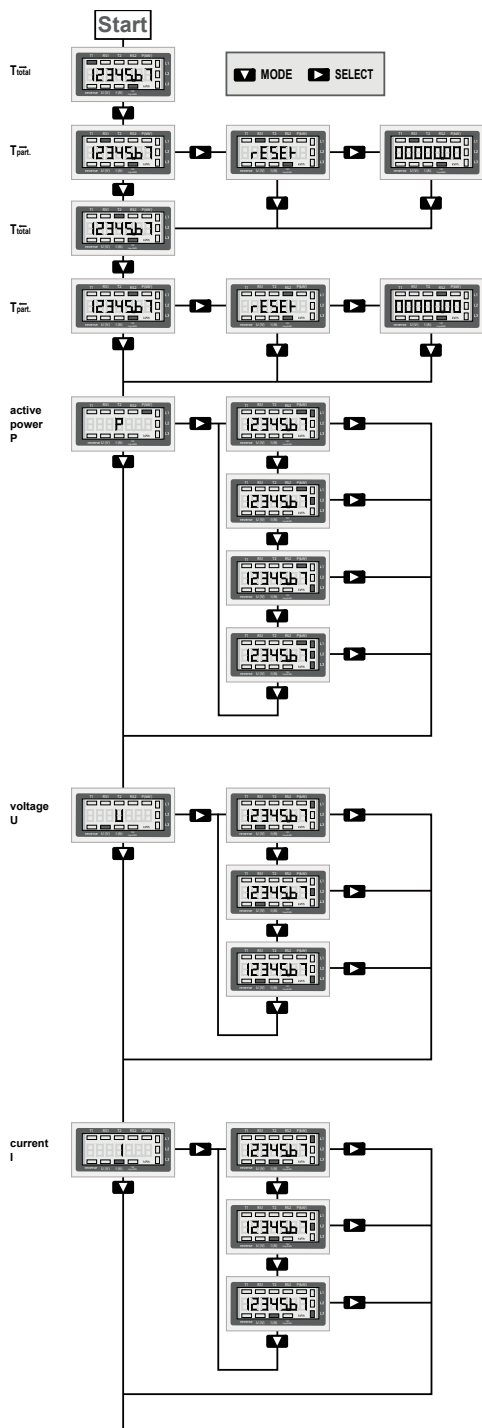

Modbus
device
address

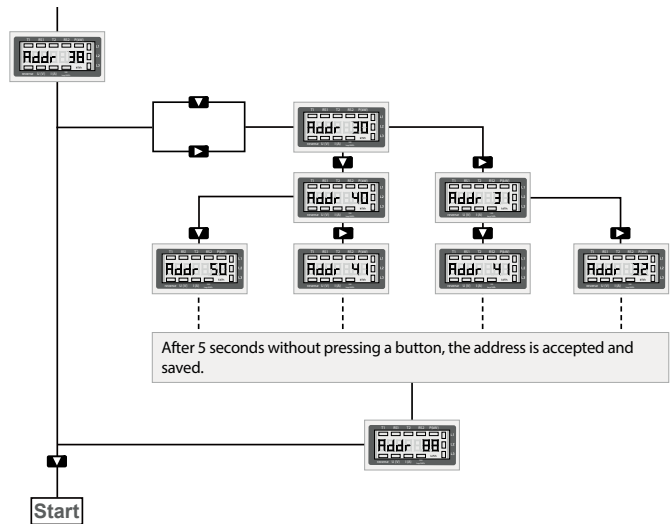

Technical data

Rated voltage, extended range	3x230/400 V, 50 Hz, -20%/+15%
Reference current I_{ref} (Limiting current I_{max})	3x0.5 - 10 (80) A
Internal consumption active power	0.5 W per path
Display	LC display 7 digits, therefrom 1 or 2 digits after the decimal point
Accuracy class $\pm 1\%$	B
Inrush current according to accuracy class B	40 mA
Operating temperature	-25/+55°C
Interface	Modbus / RTU (RS485)
Terminal cover sealable	Terminal cover claps
Protection degree	IP50 for mounting in distribution cabins with protection class IP51
Maximum conductor cross section ¹⁾	L terminals 25 mm ² , N terminals 16 mm ² , Bus terminals 6 mm ²
Recommended torque ²⁾	L terminals 2,0 Nm (max. 2,5 Nm) N terminals 1,5 Nm (max. 2,0 Nm) Bus terminals 0,8 Nm (max. 1.2 Nm)
EC type examination certificate	0120/SGS0204
The energy meter is used indoors.	
Mechanical environmental conditions	class M1
Electromagnetic environmental conditions	class E2

¹⁾ The carrying capacity of cables and wires is defined in DIN VDE 0298-4.

²⁾ The torques for screw terminals are mentioned in DIN EN 60999-1.

To avoid damages at the energy meter, the recommended torque values for each terminal must not be exceeded!

EC DECLARATION OF CONFORMITY

Product **Modbus two-way three-phase energy meter, MID approval**

Type designation **DSZ15DZMOD-3x80A**

EC-type examination **0120/SGS0204**
certificate

The manufacturer herewith declares, on his own responsibility that the designated products which this certificate refers to, are in accordance with the following harmonized standards or normative documents as well as with the following Directives of the European Parliament and of the Council (relevant version):

DIN EN 50470 part 1: 2019-08 and part 3: 2020-03 (electronic meters)
2014 / 32 / EU measuring instruments
2014 / 30 / EU electromagnetic compatibility
2011 / 65 / EU restriction of the use of certain hazardous substances (RoHS Directive)

The designated products are placed on the market by ELTAKO GmbH ,
Hofener Straße 54 , 70736 Fellbach, Germany.

Notified body **SGS Fimko OY, No. 0598**
Takomotie 8, FI-00380 Helsinki, Finland

Manufacturer **Shenzhen Chuangren Technology Co. Ltd.**
Building 33, No.3 Industrial Area, Mashantou, Gongming Street,
New Guangming District, Shenzhen City, Guangdong Province, 518106, China

Place, Date **Shenzhen, 07 July 2023**

Signature



This declaration proves the compliance with the above-mentioned EC Directives but it does not include any assurance of properties.
Security advices of the provided product information have to be noticed.

Documentation Modbus parameters:



[http://eltako.com/redirect/Modbus-RTU_protocol_specification_for_DSZ15DZMOD_V1.6_English version](http://eltako.com/redirect/Modbus-RTU_protocol_specification_for_DSZ15DZMOD_V1.6_English%20version)

Manuals and documents in further languages:



http://eltako.com/redirect/DSZ15DZMOD-3*80A_MID



Must be kept for later use!

We recommend the housing for operating instructions GBA14.

Eltako GmbH

D-70736 Fellbach

Technical Support English:

+49 711 94350025

technical-support@eltako.de

eltako.com