



28 305 712 - 5



RS485 bus three-phase meter for current transformers DSZ14WDRS-3x5A with display and MID approval

Only skilled electricians may install this electrical equipment otherwise there is the risk of fire or electric shock!

Temperature at mounting location: -25°C up to +55°C.
Storage temperature: -25°C up to +70°C.
Relative humidity: annual average value <75%.

valid for devices from production week 33/23
(see bottom side of housing)

RS485 bus three-phase meter for current transformers with settable CT ratio and MID. Maximum current 3x5 A. Standby loss 0,8 W at L1 and only 0,5 W at L2 and L3 each.

Modulair device for DIN-EN 60715 TH35 rail mounting in distribution cabinets with IP51 protection class. 4 modules = 70 mm wide and 58 mm deep.
Accuracy class B (1%). With RS485 interface.

This three-phase energy meter measures active energy by means of the current between input and output. The internal power consumption of 0,8 W or 0,5 W active power per path is neither metered nor indicated.

1, 2 or 3 phase conductors with max. currents up to 5 A can be connected.

The inrush current is 10 mA.

The terminals I/L1 and N must always be connected.

Connection via a FBA14 to the Eltako RS485 bus with a 2-wire shielded bus cable (telephone cable). For the **last** meter in the RS485 bus, the enclosed terminating resistor (120 Ω) must be connected to the RSA/RSB terminals. The meter reading and the momentary capacity are transferred to the bus – e.g. for transfer to an external computer or a controller – and is also transferred to the wireless network via the FAM14.

The consumption value is stored in non-volatile memory and is displayed again immediately after a power failure.

The 7 segment LC display is also legible twice within a period of 2 weeks without power supply.

The power consumption is displayed with a LED flashing 10 times per kWh next to the display. On the right next to the display are the keys MODE and SELECT. Press them to scroll through the menu. First the **background lighting** switches on. The display then shows the total active energy, the active energy of the resettable memory as well as the instantaneous values of consumption, voltage and current per phase.

The CT ratio can also be set. It is set to 5:5 at the factory and blocked with a bridge over the terminals which are marked with 'JUMPER'. To adjust the CT ratio to the installed transformer remove the bridge and reset the energy meter according to the operation manual. Then block it again with the bridge. Adjustable current transformer ratios: 5:5, 50:5, 100:5, 150:5, 200:5, 250:5, 300:5, 400:5, 500:5, 600:5, 750:5, 1000:5, 1250:5 and 1500:5.

Error message (false)

When the phase conductor is missing or the current direction is wrong 'false' and the

corresponding phase conductor are indicated on the display.

Important! Before working on the current transformers disconnect the voltage paths of the energy meters.

A device address for the DSZ14 has to be assigned from the FAM14, to hand the telegrams of the DSZ14 over to the bus.

Assign device address for the DSZ14:

Normal display: Briefly press the SELECT button, the backlight is switched on. If the SELECT button is pressed longer than 3 seconds, the device address appears in the display. Now turn the rotary switch on the FAM14 to position 1 within 60 seconds, its lower LED flashes red. Once the address is assigned by the FAM14, its lower LED lights green for 5 seconds and the normal display appears again on the DSZ14.

Delete device address of the DSZ14:

Normal display: Briefly press the SELECT button, the backlight is switched on. If the SELECT button is pressed longer than 3 seconds, the device address appears in the display. Now hold the SELECT button for 5 seconds, the device address is set to zero.

Transmit teach-in telegram:

Normal display: Briefly press the SELECT button, the backlight is switched on. If the SELECT button is pressed longer than 3 seconds, the device address appears in the display.

By briefly pressing the MODE button, a teach-in telegram and a data telegram is sent. The FAM14 has to be operated in position 2 or 5, to sent the telegrams of the DSZ14 into the Eltako Wireless Building.

A data telegram containing meter reading, power and serial number is automatically sent and cyclically transmitted every 10 minutes after switching on the supply voltage.

If you change the meter reading by 0.1 kWh, the meter reading telegram is sent.

PcH is the value (factory setting 200 watts) of the power change required for the meter to send a power telegram immediately.

Change PcH value:

Short press the MODE button, the backlight will turn on.

Then press the MODE button repeatedly until PcH appears on the display.

Now briefly press the MODE and SELECT buttons together. The first digit of the number flashes. MODE increases the number and SELECT decreases the number. Between 10 to 100 in increments of 10 and from 100 to 1000 in increments of 100. If no more keys are pressed, the current value is saved after 5 seconds. With MODE you get back to the normal display.

The DSZ14 can be read-out with the PC tool PCT14.

The serial number, meter reading and resettable meter reading will be displayed.

Meter special operating modes:

In the meter operating modes of the FAM14, the focus is on the adjustable transmission speed of electricity meter data for external building energy managers.

Data can be accessed and forwarded via gateways connected to the FAM14 (FGW14, FGW14-USB, FGW14W(L)-IP).

Additional setting options are available on the FAM14 **for meters from production week 33/23.**

Typical connection:

4-wire-connection 3x230/400 V

Connect the current transformer terminals on the secondary part to the phase conductors which are metered. These connections for the voltage supply of the energy meters must be secured according to the local installation regulations.

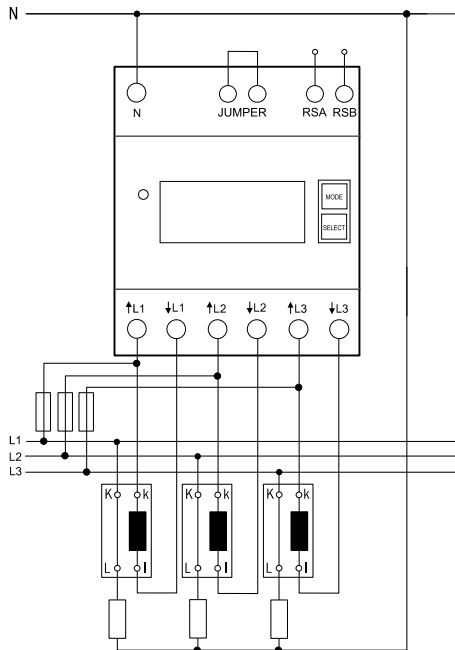

Technical data

Rated voltage, extended range	3x230/400 V, 50 Hz, -20%/+15%
Reference current I_{ref} (Limiting current I_{max})	3x0,05 - 5(6)A
Internal consumption active power	0,8 W at L1 and only 0,5 W at L2 and L3
Display	LC display 7 digits, therefrom 1 digit after the decimal point
Accuracy class $\pm 1\%$	B
Inrush current according to accuracy class B	10 mA
Operating temperature	-25/+55°C
Interface	RS485 bus series 14
Terminal cover sealable	Terminal cover claps
Protection degree	IP50 for mounting in distribution cabins with protection class IP51
Maximum conductor cross section ¹⁾	N and L terminals 16 mm ² , RSA/RSB terminals and jumper terminals 6 mm ²
Recommended torque ²⁾	L- and N terminals 1,5 Nm (max. 2,0 Nm) RSA/RSB terminals and jumper terminals 0,8 Nm (max. 1,2 Nm)
EC type examination certificate	0120/SGS0314
The energy meter is used indoors	
Mechanical environmental conditions	class M1
Electromagnetic environmental conditions class	class E2

¹⁾ The carrying capacity of cables and wires is defined in DIN VDE 0298-4.

²⁾ The torques for screw terminals are mentioned in DIN EN 60999-1.

To avoid damages at the energy meter, the recommended torque values for each terminal must not be exceeded!

Manuals and documents in further languages:



http://eltako.com/redirect/DSZ14WDRS-3*5A_MID



Menu guidance

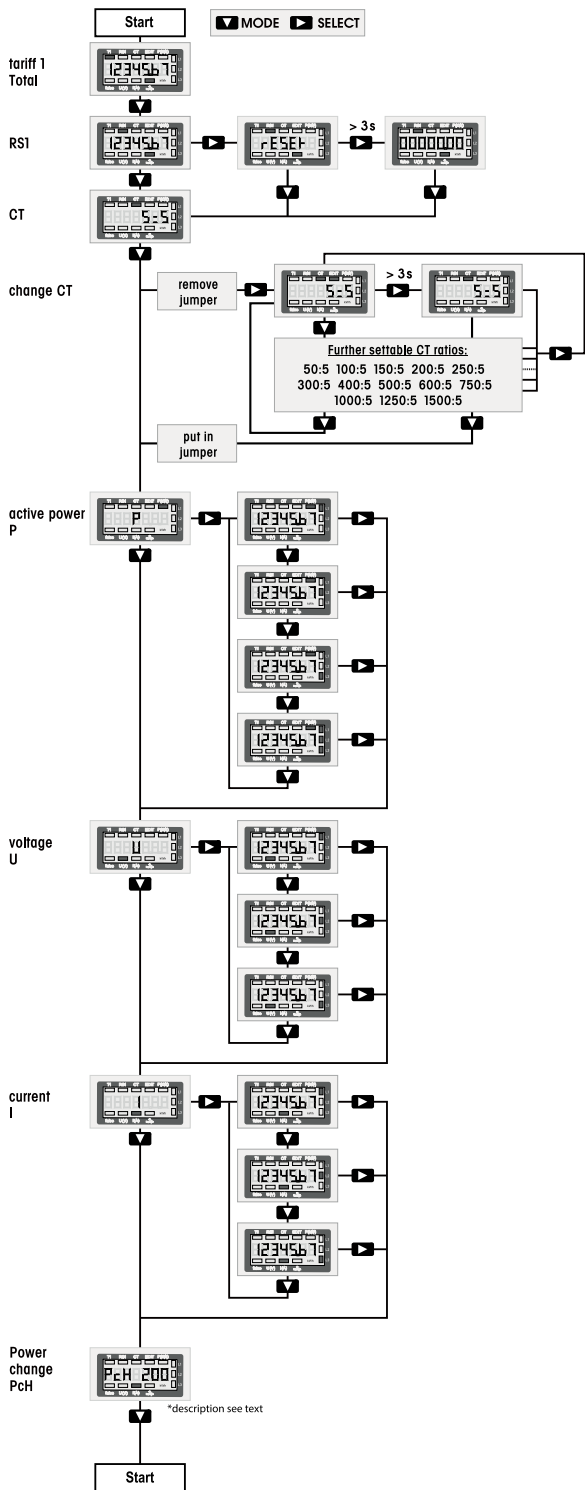

EC DECLARATION OF CONFORMITY

Product **Calibrated electronic RS485 three-phase energy meter with MID approval**
 CT operated energy meter with settable CT ratio

Type designation **DSZ14WDRS-3x5A**

EC-type examination 0120/SGS0314
 certificate

The manufacturer herewith declares, on his own responsibility that the designated products which this certificate refers to, are in accordance with the following harmonized standards or normative documents as well as with the following Directives of the European Parliament and of the Council (relevant version):

DIN EN 50470 part 1: 2019-08 and part 3: 2020-03 (electronic meters)
 2014 / 32 / EU measuring instruments
 2014 / 30 / EU electromagnetic compatibility
 2011 / 65 / EU restriction of the use of certain hazardous substances (RoHS Directive)

The designated products are placed on the market by ELTAKO GmbH ,
 Hofener Straße 54 , 70736 Fellbach, Germany.

Notified body SGS Fimko OY, No. 0598
 Takomotie 8, FI-00380 Helsinki, Finland

Manufacturer Shenzhen Chuangren Technology Co. Ltd.
 Building 33, No.3 Industrial Area, Mashantou, Gongming Street,
 New Guangming District, Shenzhen City, Guangdong Province, 518106, China

Place, Date Shenzhen, 25 February 2021

Signature



This declaration proves the compliance with the above-mentioned EC Directives but it does not include any assurance of properties.
 Security advices of the provided product information have to be noticed.

Must be kept for later use!

We recommend the housing for operating instructions GBA14.

Eltako GmbH

D-70736 Fellbach

Technical Support English:

+49 711 94350025

technical-support@eltako.de

eltako.com