

Two-way three-phase energy meter DSZ14WDRS-3x5A with display and MID approval



Only skilled electricians may install this electrical equipment otherwise there is the risk of fire or electric shock!

Temperature at mounting location: -25°C up to +55°C.
Storage temperature: -25°C up to +70°C.
Relative humidity: annual average value <75%.

Two-way three-phase energy meter with settable CT ratio and MID. Maximum current 3x5A. Standby loss 0,8W at L1 and only 0,5W at L2 and L3 each.

Modulair device for DIN-EN 60715 TH35 rail mounting in distribution cabinets with IP51 protection class.

4 modules = 70mm wide and 58mm deep.

Accuracy class B (1%). With RS485 interface.

This three-phase energy meter measures active energy by means of the current between input and output.

The internal power consumption of 0,8W or 0,5W active power per path is neither metered nor indicated.

1, 2 or 3 phase conductors with max. currents up to 5A can be connected.

The inrush current is 10mA.

The terminals I1 and N must always be connected.

Connection via a FBA14 to the Eltako RS485 bus with a 2-wire shielded bus cable (telephone cable). The meter reading and the momentary capacity are transferred to the bus – e.g. for transfer to an external computer of the GFVS 3.0 Software – and is also transferred to the wireless network via the FAM14. Display also using FEA65D.

The 7 segment LC display is also legible twice within a period of 2 weeks without power supply.

The power consumption is displayed with a LED flashing 10 times per kWh next to the display.

On the right next to the display are the keys MODE and SELECT. Press them to scroll through the menu. First the **background lighting** switches on. The display then shows the total active energy, the active energy of the resettable memory as well as the instantaneous values of consumption, voltage and current per phase

The CT ratio can also be set. It is set to 5:5 at the factory and blocked with a bridge over the terminals which are marked with 'JUMPER'. To adjust the CT ratio to the installed transformer remove the bridge and reset the energy meter according to the operation manual. Then block it again with the bridge.

Adjustable current transformer ratios: 5:5, 50:5, 100:5, 150:5, 200:5, 250:5, 300:5, 400:5, 500:5, 600:5, 750:5, 1000:5, 1250:5 and 1500:5.

Error message (false)

When the phase conductor is missing or the current direction is wrong 'false' and the corresponding phase conductor are indicated on the display.

Important! Before working on the current transformers disconnect the voltage paths of the energy meters.

A device address for the DSZ14 has to be assigned from the FAM14, to hand the telegrams of the DSZ14 over to the bus.

Assign device address for the DSZ14:

Normal display: Briefly press the SELECT button, the backlight is switched on. If the SELECT button is pressed longer than 3 seconds, the device address appears in the display. Now turn the rotary switch on the FAM14 to position 1 within 60 seconds, its lower LED flashes red. Once the address is assigned by the FAM14, its lower LED lights green for 5 seconds and the normal display appears again on the DSZ14.

Delete device address of the DSZ14:

Normal display: Briefly press the SELECT button, the backlight is switched on. If the SELECT button is pressed longer than 3 seconds, the device address appears in the display. Now hold the SELECT button for 5 seconds, the device address is set to zero.

Transmit teach-in telegram:

Normal display: Briefly press the SELECT button, the backlight is switched on. If the SELECT button is pressed longer than 3 seconds, the device address appears in the display.

By briefly pressing the MODE button, a teach-in telegram and a data telegram is sent. The FAM14 has to be operated in position 2 or 5, to sent the telegrams of the DSZ14 into the Eltako Wireless Building.

A data telegram containing meter reading, power and serial number is automatically sent and cyclically transmitted every 10 minutes after switching on the supply voltage.

If you change the meter reading by 0.1 kWh, the meter reading telegram is sent.

Within 20 seconds after a change in power of at least 10%, a power telegram is sent.

The DSZ14 can be read-out with the PC tool PCT14.

The serial number, meter reading and resettable meter reading will be displayed.

Typical connection:

4-wire-connection 3x230/400V

Connect the current transformer terminals on the secondary part to the phase conductors which are metered. These connections for the voltage supply of the energy meters must be secured according to the local installation regulations.

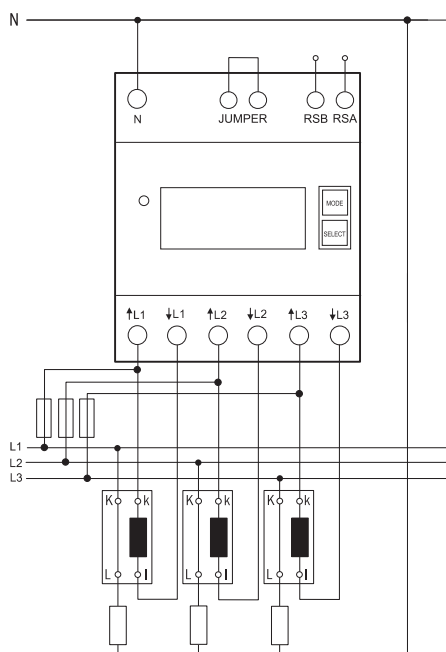

Technical data

Rated voltage, extended range	3x230/400V, 50Hz, -20%/+15%
Reference current I_{ref} (Limiting current I_{max})	3x5 (6)A
Internal consumption active power	0,8W at L1 and only 0,5W at L2 and L3
Display	LC display 7 digits, therefrom 1 digit after the decimal point
Accuracy class $\pm 1\%$	B
Inrush current according to accuracy class B	10mA
Operating temperature	- 25/+55°C
Interface	RS485 bus Series 14
Terminal cover sealable	Terminal cover claps
Protection degree	IP50 for mounting in distribution cabinets with protection class IP51
Maximum conductor cross section	N and L terminals 16 mm ² , RSA/RSB terminals 6 mm ²
EC type examination certificate	CH-MI003-08009
Mechanical environmental conditions	class M2
Electromagnetic environmental conditions class	class E2

Menu guidance

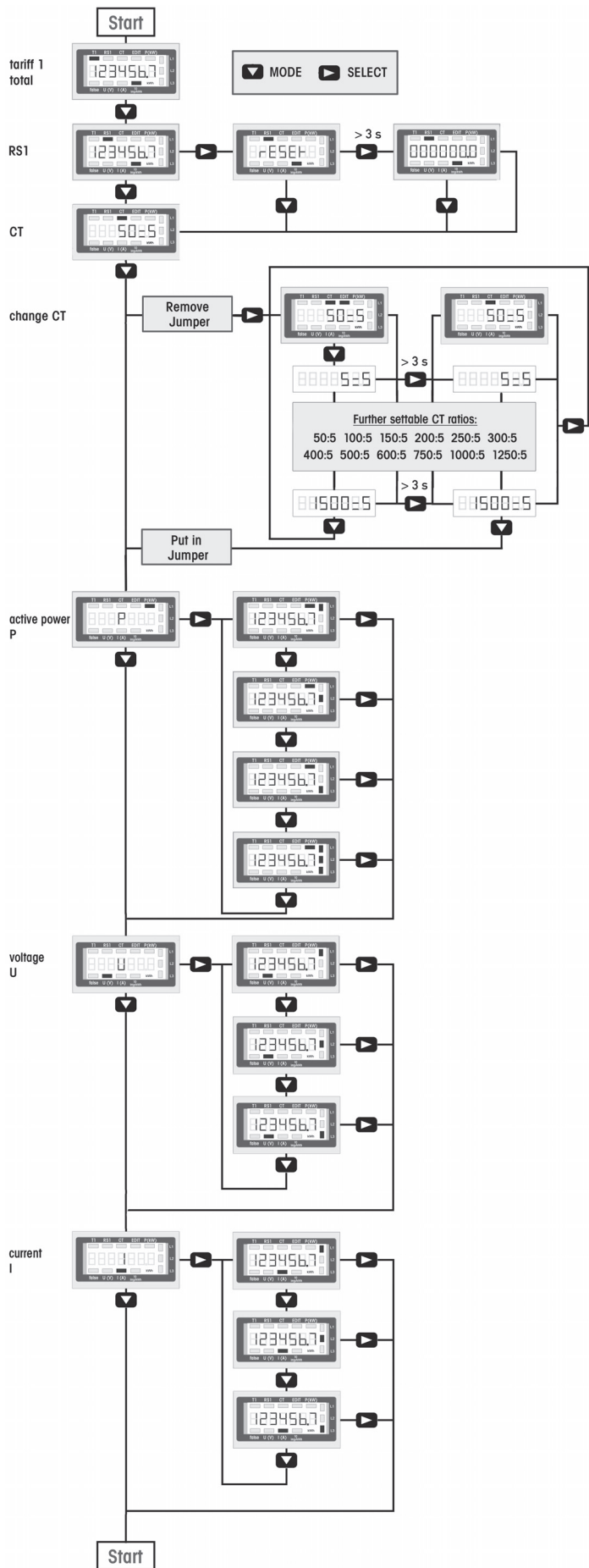

EC DECLARATION OF CONFORMITY

File name	FQKZ116
Product	Calibrated electronic RS485 three-phase energy meter with display and MID approval CT operated energy meter with settable CT ratio
Type designation	DSZ14WDRS-3x5A
EC type examination certificate	CH-MI003-08009

Eltako GmbH, D - 70736 Fellbach, herewith declares, on their own responsibility that the energy meter which this certificate refers to, is in accordance with the following standards:

EN 50470 parts 1 and 3: October 2006 (electronic meters)

Directive 2004/22/EG of the European parliament and of the Council on measuring instruments

- Annex I, essential requirements
- Annex MI-003, active electrical energy meters

Conformity assessment body: Certification body METAS-Cert, no. 1259
CH-3003 Bern-Wabern

Issuer: Eltako GmbH
Hofener Straße 54, D-70736 Fellbach
Place, Date: Fellbach, 27. september 2012
signed: Ulrich Ziegler, General Manager

Must be kept for later use!

We recommend the housing for operating instructions GBA14.

Eltako GmbH

D-70736 Fellbach
+49 711 94350000
www.eltako.com

45/2014 Subject to change without notice.