

Three-phase energy meter DSZ14DRS-3x80A  
with display and MID approval



**Only skilled electricians may install this electrical equipment otherwise there is the risk of fire or electric shock!**

Temperature at mounting location: -25°C up to +55°C.  
Storage temperature: -25°C up to +70°C.  
Relative humidity: annual average value <75%.

### Three-phase energy meter.

**Maximum current 3x80A. Standby loss 0,8W at L1 and only 0,5W at L2 and L3 each.**

Modulair device for DIN-EN 60715 TH35 rail mounting in distribution cabinets with IP 51 protection class.

4 modules = 70mm wide and 58mm deep.

Accuracy class B (1%). With RS485 interface.

It measures active energy by means of the current between input and output. The internal power consumption of 0,8W or 0,5W active power per path is neither metered nor indicated.

1, 2 or 3 phase conductors with max. currents up to 80A can be connected. The inrush current is 40 mA.

The terminals 1L1 and N must always be connected.

**Connection via a FBA14 to the Eltako RS485 bus with a 2-wire shielded bus cable (telephone cable).** The meter reading and the momentary capacity are transferred to the bus – e.g. for transfer to an external computer of the GFVS 3.0 Software – and is also transferred to the wireless network via the FAM14. Display also using FEA65D.

**The 7 segment LC display is also legible twice within a period of 2 weeks without power supply.**

Power consumption is indicated using a LED next to the display flashing 1000 times per kWh.

**Designed as standard for using as double-tariff meter:** Switch over to a second tariff by applying 230V to terminals E1/E2.

On the right next to the display are the keys MODE and SELECT. Press them to scroll through the menu. First the **background lighting** switches on. The display then shows the total active energy per tariff, the active energy of the resettable memory RS1 or RS2 as well as the instantaneous values of consumption, voltage and current per phase.

### Error message (false)

When the phase conductor is missing or the current direction is wrong 'false' and the corresponding phase conductor are indicated on the display.

A device address for the DSZ14 has to be assigned from the FAM14, to hand the telegrams of the DSZ14 over to the bus.

### Assign device address for the DSZ14:

Normal display: Briefly press the SELECT button, the backlight is switched on. If the SELECT button is pressed longer than 3 seconds, the device address appears in the display. Now turn the rotary switch on the FAM14 to position 1 within 60 seconds, its lower LED flashes red. Once the address is assigned by the FAM14, its lower LED lights green for 5 seconds and the normal display appears again on the DSZ14.

### Delete device address of the DSZ14:

Normal display: Briefly press the SELECT button, the backlight is switched on. If the SELECT button is pressed longer than 3 seconds, the device address appears in the display. Now hold the SELECT button for 5 seconds, the device address is set to zero.

### Transmit teach-in telegram:

Normal display: Briefly press the SELECT button, the backlight is switched on. If the SELECT button is pressed longer than 3 seconds, the device address appears in the display.

By briefly pressing the MODE button, a teach-in telegram and a data telegram is sent. The FAM14 has to be operated in position 2 or 5, to sent the telegrams of the DSZ14 into the Eltako Wireless Building.

A data telegram containing meter reading, power and serial number is automatically sent and cyclically transmitted every 10 minutes after switching on the supply voltage.

If you change the meter reading by 0.1 kWh, the meter reading telegram is sent.

Within 20 seconds after a change in power of at least 10%, a power telegram is sent.

The DSZ14 can be read-out with the PC tool PCT14.

The serial number, meter reading tariff 1, resettable meter reading tariff 1, meter reading tariff 2 and resettable meter reading tariff 2 will be displayed.

### Menu guidance

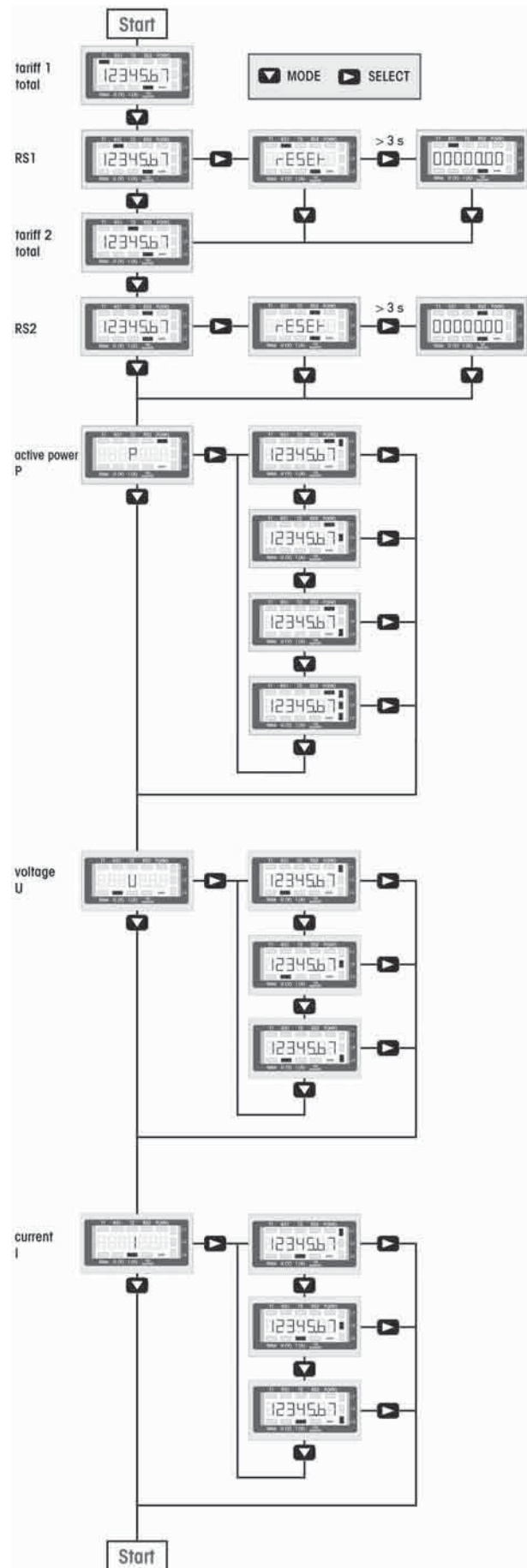

**Typical connection:**

4-wire-connection 3x230/400V

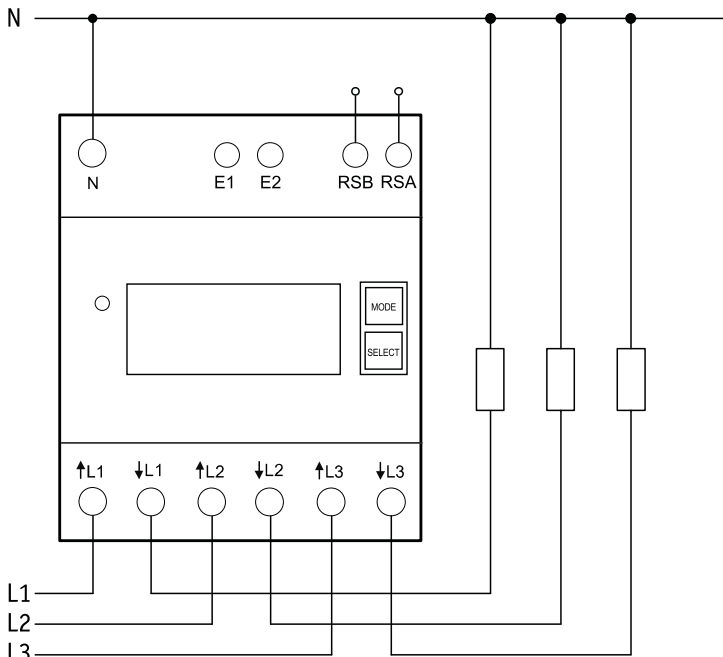
**Technical data**

Rated voltage, extended range	3x230/400V, 50Hz, -20%/+15%
Reference current $I_{ref}$ (Limiting current $I_{max}$ )	3x0.5 - 10(80)A
Internal consumption active power	0,8W at L1 and only 0,5W at L2 and L3
Display	LC display 7 digits, therefrom 1 or 2 digits after the decimal point
Accuracy class $\pm 1\%$	B
Inrush current according to accuracy class B	40mA
Operating temperature	-25/+55°C
Interface	RS485 bus Series 14
Terminal cover sealable	Terminal cover claps
Protection degree	IP50 for mounting in distribution cabins with protection class IP51
Maximum conductor cross section <sup>1)</sup>	L terminals 25 mm <sup>2</sup> , N terminals 16 mm <sup>2</sup> , RSA/RSB terminals and tariff terminals 6 mm <sup>2</sup>
Recommended torque <sup>2)</sup>	L terminals 2,0Nm (max. 2,5Nm) N terminals 1,5Nm (max. 2,0Nm) RSA/RSB terminals and tariff terminals 0,8Nm (max. 1,2Nm)
EC type examination certificate	0120/SGS0204

The energy meter is used indoors.

Mechanical environmental conditions	class M1
Electromagnetic environmental conditions	class E2

<sup>1)</sup> The carrying capacity of cables and wires is defined in DIN VDE 0298-4.

<sup>2)</sup> The torques for screw terminals are mentioned in DIN EN 60999-1.

**To avoid damages at the energy meter, the recommended torque values for each terminal must not be exceeded!**

**EC DECLARATION OF CONFORMITY**

File name	FQKZ060-CR
Product	Calibrated electronic RS485 three-phase energy meter with MID approval
Type designation	DSZ14DRS-3x80A
EC-type examination certificate	0120/SGS0204

The manufacturer herewith declares, on his own responsibility that the designated products which this certificate refers to, are in accordance with the following harmonized standards or normative documents as well as with the following Directives of the European Parliament and of the Council ( relevant version ):

DIN EN 50470	parts 1 and 3 : May 2007 ( electronic meters )
2014 / 32 / EU	measuring instruments
2014 / 30 / EU	electromagnetic compatibility
2011 / 65 / EU	restriction of the use of certain hazardous substances ( RoHS Directive )

The designated products are placed on the market by ELTAKO GmbH ,  
Hofener Straße 54 , 70736 Fellbach, Germany.

Notified body SGS United Kingdom Limited , No. 0120  
Unit 202B Worle Parkway, Weston-super-Mare, BS22 6WA. UK

Manufacturer Shenzhen Chuangren Technology Co. Ltd.  
Building 33, No.3 Industrial Area, Mashantou, Gongming Street,  
New Guangming District, Shenzhen City, Guangdong Province, 518106, China

Place, Date Shenzhen, 02 January 2018

Signature



This declaration proves the compliance with the above-mentioned EC Directives but it does not include any assurance of properties.  
Security advices of the provided product information have to be noticed.

**Must be kept for later use!**

We recommend the housing for operating instructions GBA12.

**Eltako GmbH**

D-70736 Fellbach

**Technical Support English:**

☎ +49 711 94350025

✉ technical-support@eltako.de

eltako.com

23/2020 Subject to change without notice.