

## FKR12UD-12V DC

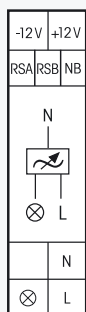

**Universal dimming actuator 1 channel, Power MOSFET up to 500W, ESL up to 100W and LED up to 100W. Only 0.3 watt standby loss. Motion-dependent and brightness-dependent light control of dimmable energy saving lamps ESL and 230V LED lamps, incandescent and halogen lamps with the wireless motion/brightness sensor FBH or wireless outdoor brightness sensor FAH.**

Modular device for DIN-EN 60715 TH35 rail mounting. 1 module = 18 mm wide, 58 mm deep. Universal dimmer switch for R, L and C loads up to 500 watts, depending on ventilation conditions. Automatic detection of load R+L or R+C. ESL and LED is manually settable. Dimmable energy saving lamps ESL up to 100 watts and dimmable 230V LED lamps up to 100 watts.

**Zero passage switching with soft ON and soft OFF to protect lamps.**

The 12V DC supply voltage of the complete RS485 bus is mainly powered at 6W, 12W or 24W by a switch mode power supply unit SNT12-12V DC that is only 1 or 2 pitch units wide. The power consumption of the 12V DC power supply is only 0.05W.

The brightness level is stored on switch-off (memory). In case of a power failure the switch position and the brightness stage are stored and may be switched on when the power supply is restored. Automatic electronic overload protection and overtemperature switch-off.

**Connection to the Eltako RS485 bus, terminals RSA and RSB.**

**Up to a total of 128 actuators can be added in this way.**

The wireless constant light controller FKR12UD receives its information from one or several wireless sensors FAH or FBH via a wireless antenna module FAM12-12V DC and then controls the output or switches the light on or off. Since incandescent lamps and halogen lamps have a large infrared percentage like daylight, these lamps can only be controlled by measuring the brightness outside the building by a wireless outdoor brightness sensor FAH acting as master. Motion detection takes place inside the room by a FBH acting as slave. Dimmable energy saving lamps and LED require only a FBH inside the room for brightness control and motion detection.

**Operating modes BA are taught-in: 1 = fully automatic ESL (for brightness-dependent and motion-dependent switch-on and switch-off of ESL), 2 = semiautomatic ESL (only for brightness-dependent and motion-dependent switch-off of ESL), 3 = switch-off of ESL is brightness-dependent (only for brightness-dependent switch-off of ESL, the motion sensor inside the FBH is then inactive), 4 = fully automatic incandescent/ halogen lamps, 5 = semiautomatic incandescent/halogen lamps, 0 = fully automatic 230V LED lamps (dimming curve 1), 10 = semiautomatic 230V LED lamps (dimming curve 1), 20 = fully automatic 230V LED lamps (dimming curve 2), 30 = semiautomatic 230V LED lamps (dimming curve 2).**

**With one wireless pushbutton or wireless hand-held transmitter the automatic system can be overloaded to a preset value in order to dim the light for a beamer presentation, for example.**

Several FBHs can be taught-in in a FKR12UD. As long as one of the motion detection sensors detects activity, the necessary lighting remains on and only after all FBHs report no activity for 1 minute does the adjustable time delay RV commence.

Only a FBH in operation mode BA 1, 2 or 3, otherwise a FAH provides constant light control. The FBHs and FAHs can also be taught-in in several FKR12s. This not only allows an increase in the total switching capacity but also the set-up of zones with different brightness settings by setting different basic brightness values GH. Several independent FKR12 systems can be installed simultaneously.

**To teach-in wireless pushbuttons and wireless hand-held transmitters, one rocker is taught-in as direction switches.** Tap the bottom part to switch the light off. Press the top or bottom to dim up or down. This shifts the control automatic towards brighter or darker. A double tap on the bottom part dims down to the taught-in value 'Beamer Presentation'. When the light is switched off and the top part is held down, the light is dimmed up from the lowest brightness level until the rocker is released. Resetting to automatic control is effected either by automatic light switch-off or by double-tapping the top direction switch.

### Function rotary switches

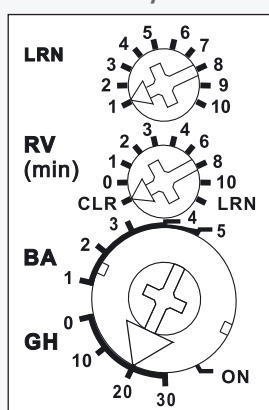

Standard setting ex works.

### Typical connection

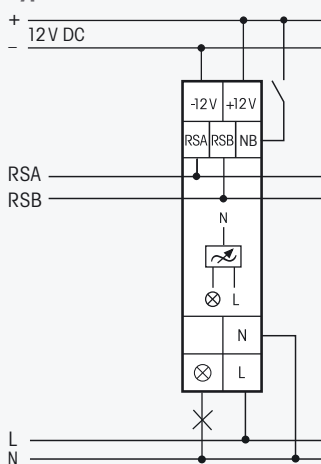

The beamer brightness can additionally be taught-in in a further universal switch. **In addition to the beamer brightness the minimum brightness and the brightness for emergency lighting can be set and stored.** As long as the control input NB is connected to +12V DC, it is dimmed to the set brightness for emergency lighting. All wireless signals are ignored then.

**The upper rotary switch LRN** is required for teach-in and for setting the base brightness. **The middle rotary switch RV** is set after teach-in to the required delay time from 0 to 10 minutes, provided a FBH is available. There is also an additional 1 minute of FBH. The base brightness **GH** dependent on use of the room is set **with the lower rotary switch plus the upper rotary switch** adding the adjusted values. The smallest settable value is 1 (0+1), the largest value is 40 (30+10). The normal setting is approx. at 21. **The LED** below the upper function rotary switch performs during the teach-in process according to the operation manual. It shows control commands by short flickering during operation.

Connection example page 4-0. Technical data, see page T-0. Housing for operating instructions GBA12 page Z-4.

FKR12UD-12V DC

RS485 bus dimming actuator constant light controller

EAN 4010312300961

56,50 €/pc.