



# The Bodyguards

Selection table bodyguards	G0
Digital adjustable operating hours impulse counter <a href="#">BRZ12DDX</a>	G1
Current relay <a href="#">AR12DX</a>	G2
Mains monitoring relay <a href="#">NR12</a>	G3
Current-limiting relay <a href="#">SBR12</a> and <a href="#">SBR61</a>	G4
Self-learning mains disconnection relay <a href="#">FR12</a>	G5
Self-learning mains disconnection relay <a href="#">FR61</a> and accessory base load <a href="#">GLE</a>	G6
Technical data and phase annunciator <a href="#">P3K12</a>	G7

# Selection Table Mains Monitoring Relays, Current Relays and Current-limiting Relays

## The Bodyguards

Eltako mains disconnection relays switch off a monitored 230V conductor after connected loads are switched off manually. This prevents interfering electromagnetic alternating fields.

A DC voltage with an extremely low residual ripple is used for monitoring purposes. No measurable alternating field is generated but it is guaranteed that room lighting is detected when switched on. The monitored conductor is then switched on again.

Electronically controlled loads or supplied loads, require a high degree of monitoring effort. Here, the self-learning mains disconnection relays are ideal for such applications.

Page		G1	G2	G3	G3	G4	G4	G5	G6	G7
	<b>pictograms</b>	<b>BZR12DDX-UC</b>	<b>AR12DX-230V</b>	<b>NR12-001-3x230V</b>	<b>NR12-002-3x230V</b>	<b>SBR12-230V/240µF</b>	<b>SBR61-230V/120µF</b>	<b>FR12-230V</b>	<b>FR61-230V</b>	<b>P3K12</b>
Modular device for mounting on DIN rail EN 60715 TH35, number of modules 18 mm each		1	1	1	2	1		1		1
Built-in device for installation (e.g. flush-mounting box)							■		■	
Number NO contacts or CO contacts potential free (not potential free)		1W	1W	1W	2W	(1)	(1)	(1)	(1)	–
Zero passage switching		■ <sup>2)</sup>	■ <sup>2)</sup>							
Switching capacity 16A/250V AC			■			■		■		–
Switching capacity 10A/250V AC		■		■	■		■		■	–
Incandescent lamp load W		2000	2300	1600	1600	1200	600	2300	1000	–
Fluorescent lamp load with EVG* and energy saving lamps W		105-200 <sup>2)</sup>	210-400 <sup>2)</sup>	$I_{on} \leq 70A / 10ms$ <sup>1)</sup>	$I_{on} \leq 70A / 10ms$ <sup>1)</sup>	1200	600	$I_{on} \leq 70A / 10ms$ <sup>1)</sup>	$I_{on} \leq 70A / 10ms$ <sup>1)</sup>	–
No standby loss						■	■			
Low standby loss		■	■	■	■			■	■	■
Adjustable operating hours counter		■								
Current relay			■							
Mains monitoring relay				■	■					
Current-limiting relay						■	■			
Mains disconnection relay								■	■	
Phase annunciator										■

\* EVG = electronic ballast units

<sup>1)</sup> A 40-fold inrush current must be expected for electronic ballast devices. Limit with SBR12 or SBR61 if applicable.

<sup>2)</sup> Duplex technology: When switched with 230V/50Hz zero passage switching is activated if L is connected to (L) and N to (N). Then additional standby loss of only 0.1 Watt.

## BZR12DDX-UC



+B1	+AR
+A1	-A2
Field 1	
Field 2	
Field 3	
(N)	2
1(L)	3

### 1 CO contact potential free 10 A/250 V AC. Standby loss 0.05–0.5 watt only.

Modular device for DIN-EN 60715 TH35 rail mounting. 1 module = 18 mm wide, 58 mm deep. **With the patented Eltako Duplex technology (DX) the normally potential-free contacts can still switch in zero passage when switching 230 V AC 50 Hz and therefore drastically reduce wear. Simply connect the neutral conductor to the terminal (N) and L to 1 (L) for this. This gives an additional standby consumption of only 0.1 watt.**

The BZR12DDX is adjustable when the supply voltage UC (8-253 V AC or 10-230 V DC) is applied to B1/A2:

Select the function by pressing the projecting buttons **MODE** and **SET**: Press MODE briefly to make the last function selected (factory setting **BST = operating hours counter**) flash in field 1. Then press SET to switch between **IMP = impulse counter up to 9999 impulses** and **I10 = impulse counter x 10 up to 99990 impulses**. Confirm the selected function by pressing MODE.

#### BST function = operating hours counter

Field 3 shows the accumulated **operating hours T1** up to 8760 hours = 1 year. Up to 999.9 hours with one decimal point. Field 2 can display up to 99 accumulated **operating years T2**. Press MODE to activate **the alarm time AZT** when the relay contact is switched over from 1-2 to 1-3. AZT flashes and SET increments each time by 1 hour in field 3. Press and hold down to change the time rapidly. Release and then press and hold down again to change the direction. Confirm the selected time by pressing MODE. The + character in field 1 displays the set alarm time. AA flashes and SET activates (display AA+) or deactivates (display AA) the automatic alarm disconnection.

The operating hours are counted in field 3 as long as the control voltage (= supply voltage) is applied to A1. The display II moves slowly to the right in field 1.

**The residual alarm time RZT** in hours can be displayed by pressing SET briefly in field 3. Press SET again to switch back to the operation display.

**If there is a power failure**, the contact switches over from 1-2 to 1-3 and may therefore be used for an alarm signal.

When the **alarm time AZT is reached**, the contact switches over from 1-2 to 1-3, SET flashes in field 1 and the display of the elapsed alarm period starts in field 2 from 0.1 minute (m) to 99 hours (h). The contact position 1-3 is indicated by an arrow on the left in field 1.

#### Typical connection

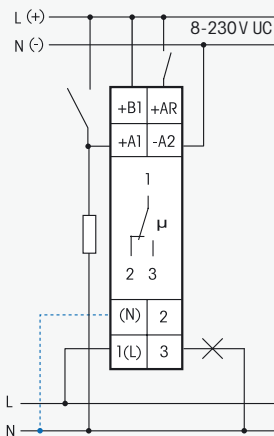

If N is connected, the zero passage switching is active.

**Acknowledge the alarm:** a) If the automatic alarm disconnection is activated (AA+), the contact 1-3 closes for only 1 second and the alarm time restarts. b) By connecting the control voltage +B1 to AR the contact switches back, if AR is disconnected from the control voltage the alarm time restarts. c) Press SET for 3 seconds to switch back the contact and to restart the alarm time. The operating hours counter in field 3 continues running same as for a) and b).

**Reset the operating hours counter** previous to the alarm signal by applying the control voltage +B1 to AR for 3 seconds or by pressing the MODE and SET buttons simultaneously for 3 seconds, confirm the RES display in field 1 by pressing SET. The counter is reset to 0. This does not change the alarm time.

**Enable the keylock** by pressing MODE and SET briefly and simultaneously. When you confirm the flashing display LCK by pressing SET, the buttons are locked and this is indicated by an arrow in field 1 pointing in the direction of the lock icon sticker.

**Disable the keylock** by pressing MODE and SET simultaneously for 2 seconds. Confirm the flashing display UNL by pressing SET to unlock.

#### IMP function = impulse counter and function I10 = impulse counter x 10

Field 3 shows the accumulated **impulses T1** up to 9999 (99990) impulses. Press MODE to **activate the alarm impulse number AIZ** when the relay contact switches over from 1-2 to 1-3. AIZ flashes and SET increments each time by 1 impulse in field 3. Press and hold down to change the impulse number rapidly. Release and then press and hold down again to change the direction. Confirm the selected impulse number by pressing MODE and the + character in field 1 to display the set alarm impulse number. Every voltage impulse (identical with the supply voltage) detected at A1 increments the number of counted impulses in field 3.

**The residual impulse number RIZ** can be displayed after pressing SET briefly. RIZ appears in field 1 and the residual impulses until the alarm is displayed in field 3. Press SET again to switch back to the operation display.

When the **alarm impulse number is reached**, the contact switches over from 1-2 to 1-3, SET flashes in field 1 and the display of other impulses up to 99 (990) starts during the alarm signal. The contact position 1-3 is indicated by an arrow on the left in field 1.

'Acknowledge alarm', 'Reset' and 'Lock/unlock setting' are identical to the BST function = operating hours counter.

Technical data page G7. Housing for operating instructions GBA12 page Z5.

**BZR12DDX-UC**

1 CO 10A

EAN 4010312603161

**51,00 €/pc.**

Recommended retail prices excluding VAT.

# Current Relay AR12DX

**AR12DX-230V**

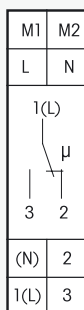

**1 CO contact potential free 16A/250V AC.**  
**Standby loss 0.8 watt only.**

Modular device for DIN 60715 TH35 rail mounting.  
 1 module = 18 mm wide, 58 mm deep.

**With the patented Eltako Duplex technology (DX) the normally potential-free contacts can still switch in zero passage when switching 230V AC 50Hz and therefore drastically reduce wear. Simply connect the neutral conductor to the terminal (N) and L to 1 (L) for this. This gives an additional standby consumption of only 0.1 Watt.**

If the contact is used for controlling switching devices which do not perform zero passage switching themselves, (N) should not be connected because the additional closing delay otherwise causes the opposite effect.

With an internal toroidal-core current transformer the single phase AC current flowing through a consumer V1 of 0.1 A up to max. 32A is compared to the setpoint. When the latter is exceeded a relay switches off a consumer V2 connected to 2 within 0.5 seconds or switches on a consumer V3 connected to 3.

Adjustment accuracy  $\pm 5\%$ . From 25A the relay always switches on.

State-of-the-art hybrid technology combines advantages of nonwearing electronic control with high capacity of special relays.

**The basis of current A** will be set with the lower rotary switch **A**.

The following basic values can be selected: 0.1 A, 0.3A, 0.6A, 0.9A, 1.5A, 1.9A, 3.0A and 3.2A.

**The multiplier xA** will be set with the middle rotary switch **xA** and offers values between 1 and 10. So currents starting from 0.1 A (basis of current 0.1 A and multiplier 1) can be set.

**OFF delay RV** can be set with the upper rotary switch **RV** between 0 and 120 secs.

The hysteresis is defined as approx. 25%.

Status indication by LED.

The measuring input M1 - M2 is electrically isolated from power supply L - N and make contact 1(L)-2/3.

Reference values larger than 32A can be adapted by an external measuring transformer.

## Function rotary switches

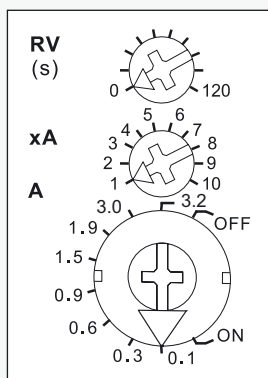

Standard setting ex factory.

## Typical connection

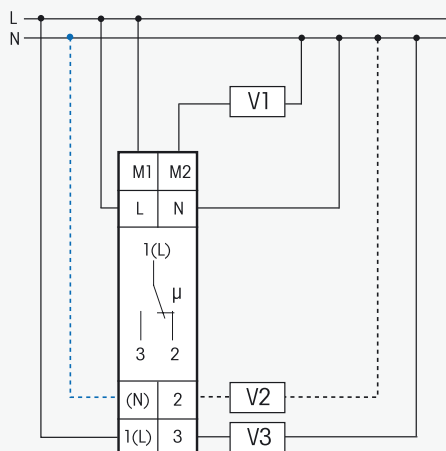

If (N) is connected, the zero passage switching is active.

Technical data page G7. Housing for operating instructions GBA12 page Z5.

**AR12DX-230V**

1 CO 16A

EAN 4010312205426

**54,30 €/pc.**

Recommended retail prices excluding VAT.

## NR12-001-3x230V

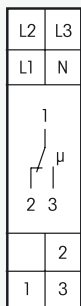

**1 CO contact potential free 10A/250V AC. Standby loss 0.8 watt only.**

Modular device for DIN 60715 TH35 rail mounting.  
1 module = 18 mm wide, 58 mm deep.

**Designed to monitor 230V AC voltage between 1 to 3 phase conductors and neutral and to monitor the rotating field (clockwise) in the switch positions 2 Ph and 3 Ph.**

In the position only the rotating field is monitored, independent from the mains voltage.

Supply voltage L1 - N 180 - 250V/50 - 60Hz.

In case of failure of L1 the relay releases immediately without delay.

With the lower rotary switch on the front two operate voltages resp. dropout voltages can be set and the number of monitored phase conductors must be selected.

**U1:** 161 V dropout voltage and 185 V operate voltage.

**U2:** 196 V dropout voltage and 206 V operate voltage as per VDE 0100, part 718 (formerly: VDE 0108, part 1).

Voltage applied signalled by LED. At wrong polarity or in case of a missing phase conductor the LED flashes rapidly.

Release delay **RV** settable with the upper rotary switch from 0.1 to 8 sec.

The LED flashes slowly during the release delay time period. Operate delay 0.5 sec.

**Maximum fusing 16A.**

### Function rotary switches

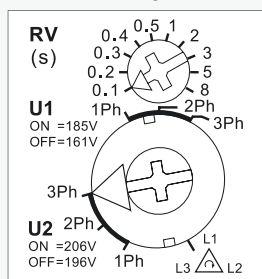

Technical data page G7. Housing for operating instructions GBA12 page Z5.

NR12-001-3x230V

1 CO 10A

EAN 4010312202524

53,00 €/pc.

## NR12-002-3x230V

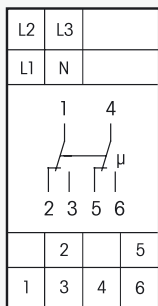

**2 CO contacts potential free 10A/250V AC. Standby loss 0.8 watt only.**

Modular device for DIN 60715 TH35 rail mounting.  
2 modules = 32 mm wide, 58 mm deep.

All functions same as NR12-001-3x230V but with a second NO contact.

**Maximum fusing 16A.**

Technical data page G7. Housing for operating instructions GBA12 page Z5.

### Typical connections: 1 phase monitoring

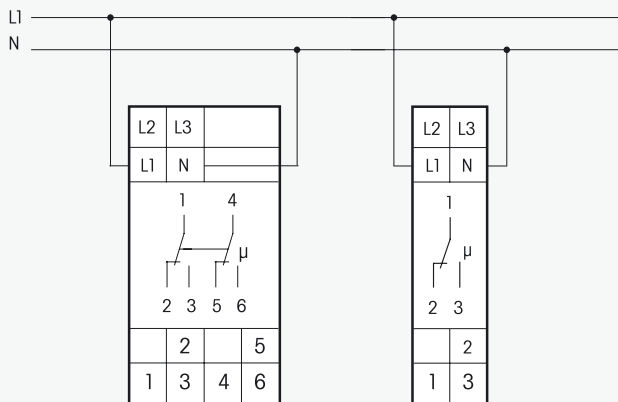

NR12-002-3x230V

NR12-001-3x230V

### 3 phase monitoring

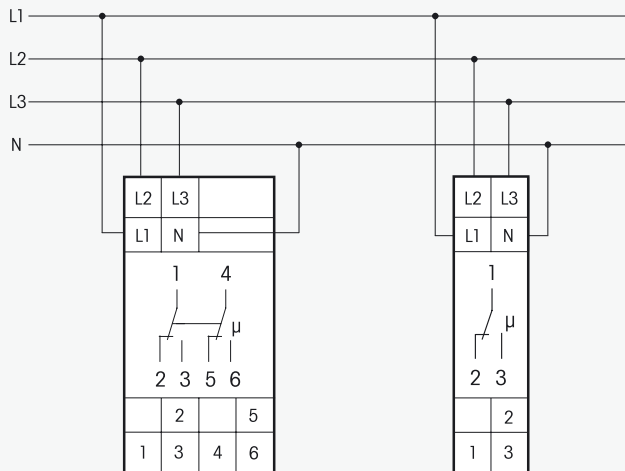

NR12-002-3x230V

NR12-001-3x230V

NR12-002-3x230V

2 CO 10A

EAN 4010312202548

62,50 €/pc.

# Current-limiting Relays Capacitive SBR

## SBR12-230V/240 μF

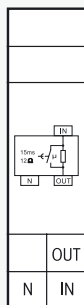

**1 NO contact 16 A/250 V AC. No standby loss.**

Modular device for DIN 60715 TH35 rail mounting.  
1 module = 18 mm wide, 58 mm deep.

**Max. capacitive load 240 μF downstream of rectifier (e.g. energy saving lamps and electronic ballast) or 120 μF directly at the mains (e.g. shunt-compensated fluorescent lamps).**

Limiting resistor 12 Ω, limiting period approx. 15 msec.

**The starting current impulse of energy saving lamps, fluorescent lamps and compact fluorescent lamps is limited to 20 A by short-time switch-on (approx. 15 msec.) of heavy-duty resistors (12 Ω).**

The current-limiting relay is connected on the load side of the protected relay contact.

Permanent load max. 1200 W, max. switching frequency 600/h.

### Typical connection

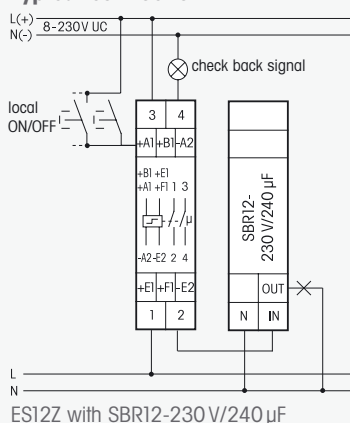

### Explanation of capacitive load specification:

The specified max. capacitive load directly at the mains is the deciding factor determining shunt-compensated fluorescent lamps or conventional ballast, for example.

Here the capacitor switched in parallel to the mains is the deciding factor determining the correct dimensioning per lamp.

The specified max. capacitive load downstream of the rectifier is the deciding factor determining fluorescent lamp ballast or energy saving lamps, for example. An equivalent capacitance of 10 μF per lamp may be calculated.

**SBR12-230V/240μF**

1 NO 16A

EAN 4010312205457

**34,60 €/pc.**

## SBR61-230V/120 μF

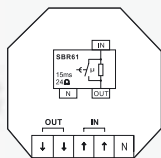

**1 NO contact 10 A/250 V AC. No standby loss.**

Built-in device for installation. 45 mm long, 55 mm wide, 18 mm deep.

**Max. capacitive load 120 μF downstream of rectifier (e.g. energy saving lamps and electronic ballast) or 60 μF directly at the mains (e.g. shunt-compensated fluorescent lamps).**

Limiting resistor 24 Ω, limiting period approx. 15 ms.

**The starting current impulse of energy saving lamps, fluorescent lamps and compact fluorescent lamps is limited to 10 A by short-time switch on (approx. 15 msec.) of heavy-duty resistors (24 Ω).**

The current-limiting relay is connected on the load side of the protected relay contact.

Permanent load max. 600 W, max. switching frequency 600/h.

### Typical connection

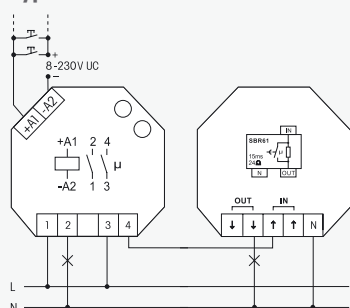

### Explanation of capacitive load specification:

The specified max. capacitive load directly at the mains is the deciding factor determining shunt-compensated fluorescent lamps or conventional ballast, for example.

Here the capacitor switched in parallel to the mains is the deciding factor determining the correct dimensioning per lamp.

The specified max. capacitive load downstream of the rectifier is the deciding factor determining fluorescent lamp ballast or energy saving lamps, for example. An equivalent capacitance of 10 μF per lamp may be calculated.

**SBR61-230V/120μF**

1 NO 10A

EAN 4010312205464

**31,10 €/pc.**

## FR12-230V

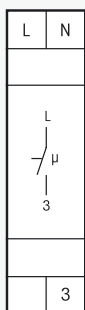

### 1 NO contact not potential free 16A/250V AC. Self-learning. Incandescent lamp load 2300W. Standby loss 0.8 watt only.

Modular device for DIN EN 60715 TH35 rail mounting.

1 module = 18mm wide and 58mm deep.

230V supply voltage and switching voltage.

State-of-the-art hybrid technology combines advantages of nonwearing electronic control with high capacity of special relays.

**The FR12-230V mains disconnection relay disconnects the power supply once all series connected loads are turned off, thus preventing any electromagnetic interference fields from occurring.**

Small loads up to 200 mA, are acceptable and, once major loads are disconnected, they do not prevent field disconnection. The limit is taught-in automatically by the FR12 using a patented method so you need not set the limit manually. Loads drawing more than 200 mA are consistently defined as loads which should cause the line power to be connected.

As long as no major load is turned on, one pole of the monitored circuit remains isolated from the mains. Neutral and earth are connected continuously to avoid acting as an aerial.

A DC voltage with an extremely low residual ripple is applied for monitoring.

Therefore, it is **prohibited to bridge the relay contact**, which would ultimately cause device failure.

When a load is turned on, the mains disconnection switch connects the monitored phase after approx. 1 sec and the LED lights red.

#### Function of the lower rotary switch

In the function ON/P-→ position, the relay contact is continuously closed and field disconnection deactivated.

Turn the switch to the position [A] = automatic with 'self-learn mode', the actual current value is saved as a switch-off value. When this value is reached, the FR12 breaks the electrical circuit regardless whether small consumers such as electronic dimmers are connected. Therefore, the lighting must always be OFF for learning by means of the rotary switch.

When the switch is in the [A] position the FR12 adapts to changes in connected consumers. The FR12 performs a new learn-in routine after phase is activated and when the power supply is restored after a power failure.

If a new small load is switched on for more than 24 hours, the total current drawn by the monitored circuit is less than 200 mA, the FR12 is set to [A] mode and in the meantime the light has been switched on and off, the new load is learned in and the conductor is switched off. When the rotary switch is set briefly from [A] to P-→, learn-in takes place immediately after connecting a new load.

If the function self-learn is not required, set the rotary switch to [X], automatic OFF.

#### Function of the upper rotary switch

The monitoring voltage can be adjusted in the range from 5V DC to 230V DC. Due to its low residual ripple, it generates no measurable alternating field even at 230V DC. The higher the adjustment, the greater the number of capacitive loads detectable without switching on a base load. It can therefore be reduced until the loads are barely detectable. In many applications, even the lowest monitoring voltages are detectable.

### Rotary switches

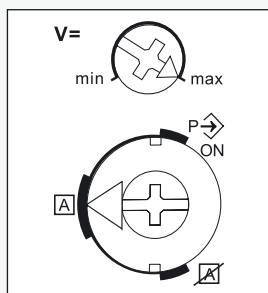

Standard setting ex factory.

### Typical connection

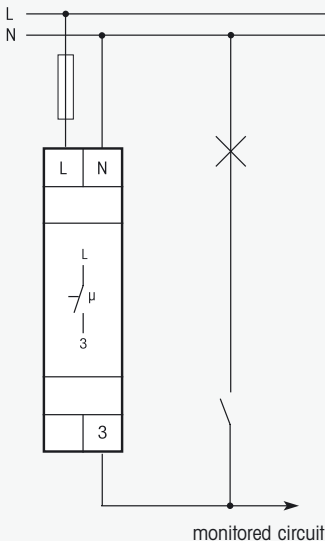

G5

# Self-learning Mains Disconnection Relay FR61, Accessory Base Load

**FR61-230 V**

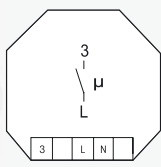

**1 NO contact not potential free 10 A/250 V AC.**  
**Standby loss 0.8 watt only.**

Built-in device for installation. 45 mm long, 55 mm wide, **26 mm deep.**

230V supply voltage and switching voltage.

State-of-the-art hybrid technology combines advantages of nonwearing electronic control with high capacity of special relays.

The FR61-230V mains disconnection relay disconnects the power supply once all series connected loads are turned off, thus preventing any electromagnetic interference fields from occurring.

Small loads up to 20 mA are acceptable and, once major loads are disconnected, they do not prevent field disconnection. There is no need to manually set the limit; it is learned by the FR61. Loads drawing more than 200 mA are consistently defined as loads which should cause the line power to be connected.

As long as no major load is turned on, one pole of the monitored circuit remains isolated from the mains. Neutral and earth are connected continuously to avoid acting as an aerial.

A DC voltage of 230V DC with an extremely low residual ripple is applied for monitoring. Therefore, it **is prohibited to bridge the relay contact**, which would ultimately cause device failure.

When a load is turned on, the mains disconnection relay connects the phase.

**If the phase is switched on for the first time and after a power failure the FR61 automatically learns in again:**

At first an inrush current of 30 mA is specified. If a new small load is switched on for more than 24 hours, the total current drawn by the monitored circuit is less than 200 mA, and in the meantime the light has been switched on and off, the new load is learned in and the conductor is switched off. This learn-in mode can be realised immediately after connection of the new load by briefly switching off the MCB.

**Typical connection**

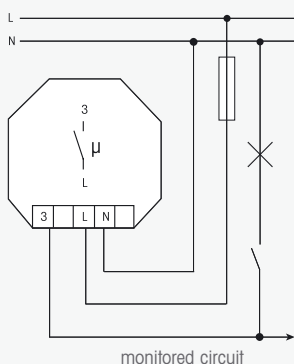

**Side view**

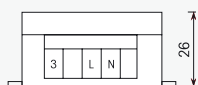

G6

Technical data page G7.

**FR61-230V**

1 NO 10A

EAN 4010312203477

**67,00 €/pc.**

**GLE**



**Accessory base load**

A base load is used if loads cannot be detected due to their capacitance but are meant to switch on the line voltage. Base loads must consistently start or operate in parallel with the related load and be turned off with the latter. Higher stand by loads may affect or jam the detection of a base load. Typical applications: Fluorescent lamps, dimmer circuits and electronic transformers.

**GLE base load element**

PTC in a small coupler with connecting leads; can be used directly in a load, a switch box or a junction box. It is not capable of keeping the mains disconnection relay in the connected state without an additional load connected.

**GLE**

1x base load

EAN 4010312900970

**5,00 €/pc.**

Recommended retail prices excluding VAT.

### P3K12

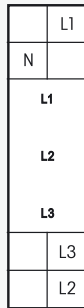

### Phase annunciator. Standby loss 0.06 watt only.

Modular device for DIN 60715 TH35 rail mounting.

1 module = 18mm wide, 58mm deep.

For visual monitoring of 1 to 3 phases 230V.

Indication with three red LEDs.

**P3K12-230V**

EAN 4010312701065

**31,10 €/pc.**

### Technical data

Contacts	BZR12DDX	NR12	AR12DX/FR12	FR61
Contact material	AgSnO <sub>2</sub> /0.5 mm	AgSnO <sub>2</sub> /0.5 mm	AgSnO <sub>2</sub> /0.5 mm	AgSnO <sub>2</sub> /0.5 mm
Spacing of control connections/contact	3 mm	> 6mm	-, AR12DX: > 6mm	-
Test voltage contact to contact	2000 V	-, NR12-002: 2000 V	-	-
Test voltage control connection to contact	-	4000 V	-, AR12DX: 4000 V	-
Rated switching capacity	10 A/250 V AC	10 A/250 V AC	16 A/250 V AC	10 A/250 V AC
Incandescent lamp and halogen lamp load <sup>1)</sup> 230V	2000 W	2000 W	2300 W	1000 W
Fluorescent lamp load with KVG* in lead-lag circuit or non compensated	1000 VA	1000 VA	1000 VA	1000 VA
Fluorescent lamp load with KVG* shunt-compensated or with EVG*	500 VA	500 VA	1000 VA	500 VA
Compact fluorescent lamps with EVG* and energy saving lamps ESL	15x7 W, 10x20W <sup>3)</sup>	I <sub>on</sub> ≤ 70A/10ms <sup>2)</sup>	I <sub>on</sub> ≤ 70A/10ms <sup>2) 3)</sup> AR12DX: 15x7 W, 10x20W <sup>3)</sup>	I <sub>on</sub> ≤ 70A/10ms <sup>2)</sup>
Max. switching current DC1: 12V/24V DC	8 A	8 A	-	-
Life at rated load, cos φ = 1 at 100/h and incandescent lamps 1000 W at 100/h	> 10 <sup>5</sup>	> 10 <sup>5</sup>	> 10 <sup>5</sup>	> 10 <sup>5</sup>
Life at rated load, cos φ = 0.6 at 100/h	> 4 x 10 <sup>4</sup>	> 4 x 10 <sup>4</sup>	> 4 x 10 <sup>4</sup>	> 4 x 10 <sup>4</sup>
Max. operating cycles	10 <sup>3</sup> /h	10 <sup>3</sup> /h	10 <sup>3</sup> /h	10 <sup>3</sup> /h
Switching position indication/voltage indication	Display	LED	LED	-
Maximum conductor cross-section	6 mm <sup>2</sup>	6 mm <sup>2</sup>	6 mm <sup>2</sup>	4 mm <sup>2</sup>
Two conductors of same cross-section	2.5 mm <sup>2</sup>	2.5 mm <sup>2</sup>	2.5 mm <sup>2</sup>	1.5 mm <sup>2</sup>
Screw head	slotted/crosshead, pozidriv	slotted/crosshead, pozidriv	slotted/crosshead, pozidriv	slotted/crosshead
Type of enclosure/terminals	IP50/IP20	IP50/IP20	IP50/IP20	IP30/IP20
<b>Electronics</b>				
Time on	100%	100%	100%	100%
Max./min. temperature at mounting location	+50°C/-20°C	+50°C/-20°C	+50°C/-20°C	+50°C/-20°C
Control voltage range	0.9 bis 1.1 x Unenn	180-250V/50-60Hz	0.9 to 1.1 x rated voltage	0.9 to 1.1 x rated voltage
Stand by loss (active power) 230V	0.5 W	0.8 W	0.8 W	0.8 W
Stand by loss (active power) 12V <sup>4)</sup>	0.05 W	-	-	-
Max. parallel capacitance (length) of control lead	0.06 μF (200m)	0.06 μF (200m)	0.06 μF (200m)	0.06 μF (200m)

\* EVG = electronic ballast units; KVG = conventional ballast units

<sup>1)</sup> Applies to lamps with max. 150W. <sup>2)</sup> A 40-fold inrush current must be expected for electronic ballast devices.

<sup>3)</sup> When using DX types close attention must be paid that zero passage switching is activated! <sup>4)</sup> Standby loss at 24V approx. two times greater than at 12V.

# Typical connections mains disconnection relays

## Standard connection mains disconnection relay

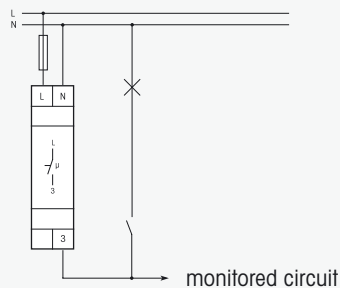

## Mains disconnection relay with GLE base load element

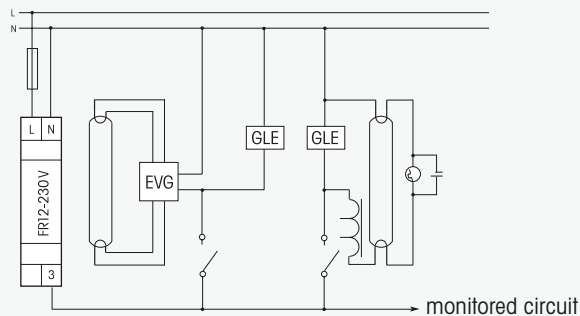

## Elder rotary dimmers with phase cut-on (ON before zero crossing) for resistive and inductive loads

Can mostly be operated at  $V=\max$  if no additional standby consumer is in the circuit. Otherwise see 'Modern dimmers'.

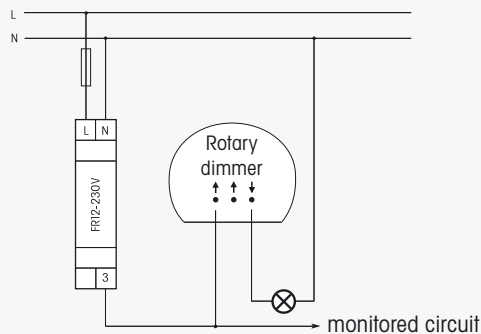

## Modern rotary dimmers and rotary dimmers with phase cut-off (OFF before zero crossing) for electronic transformers

Only dimmers with an additional terminal mains disconnection switch can be used.

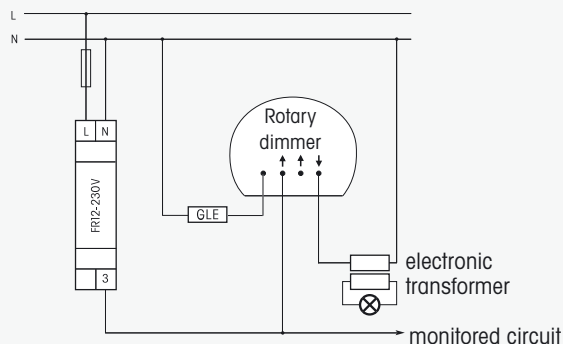

**Touch dimmers and sensor dimmers** cannot be used. The universal dimmer switch EUD61 and a push-button from the associated switch product range can replace a touch dimmer.

## Remote control dimmers

We recommend as remote control dimmers the impulse dimmer switch EUD12F. On these devices, terminal L is 'tapped' **ahead** of the mains disconnection relay, thus, maintaining the complete function. An integrated cut-off relay takes over the mains disconnection of the circuit.

Mechanical push-buttons are connected to T1 and T2. Only a low DC voltage is impressed on the control wire.

If the application of the EUD12F is not possible for reasons of installation the type EUD12NPN can be used. Here the terminal L is connected **after** the mains disconnection relay. Therefore the memory function is switched off.

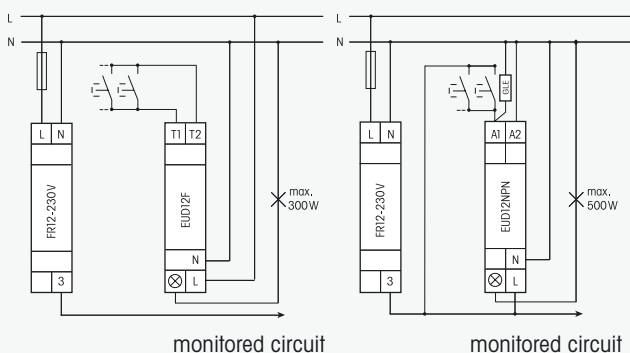

## Switched-mode power supplies in consumer electronic units (e.g. TV sets) and plug-in power supply units

Only specific units or power supplies are detected and disconnected by the mains disconnection switch, even while in standby mode. Where units or power supplies in a monitored circuit are not to be disconnected these must be isolated from line power by a switched socket outlet or a plug connector so that the function of the mains disconnection switch is not affected.

## Switching power supply units in the distribution box

The switching power supply units WNT12 are detected at primary switching-on from 50V DC monitoring voltage. At secondary switching-on of the load the full monitoring voltage is necessary.

## Roller shutter control

In order to operate tube-mounted motors with electronic limit switches, it is best if the lighting is switched on to reactivate the monitored circuit before the electromechanical switch or push-button switch is operated.

In case of automatic controls in monitored circuits, the mains disconnection (MD) must be inhibited for the period when the roller shutters are controlled. This can be achieved by fitting a time switch in the distributor.

However, in this case, do not bridge L-3 of the mains disconnection relay under any circumstances. Instead, connect the time switch change-over contact between terminal L of the MD and the monitored circuit.

## Plug-in consumers with power control

These devices (vacuum-cleaners, standard lamps with dimmer) are often not detected when switching on the mains disconnection relay. For operation of these kind of devices therefore the normal lighting must be switched on first.

## **Function check?**

Disconnect terminal 3 with the power on. The mains disconnection relay must switch the phase on. The LED goes out.

## **Base load?**

A base load is used if loads cannot be detected due to their capacitance but are meant to switch on the line voltage. Never connect a base load directly between the disconnecting phase and neutral.

## **The mains disconnection relay is clocking?**

A base load device may be connected directly between the disconnecting phase and neutral. An inductive consumer (e.g. plug-in power supply) is located in the disconnecting circuit without any isolation directly downstream of the mains disconnection relay. To function correctly, the consumer must be isolated from the mains.

## **Dimmer operation downstream of a mains disconnection relay?**

We recommend using the universal dimmer switch EUD12F or EUD12NPN, as described on page G8. Rotary dimmer with phase sector control for electronic transformers: only possible with additional terminal for mains disconnection devices (e.g. make Busch-Jaeger, Jung, Berker und Gira). Touch dimmers and sensor dimmers cannot be used. The universal dimmer switch EUD61 and a push-button from the associated switch product range can replace a touch dimmer.

## **Operate electronic transformers?**

All electronic transformers must be switched with a base load in parallel to the primary input, as long as they are not dimmed.

## **Appliances with transformer power supplies (i.e. entertainment electronic appliances, PC, etc.)?**

These appliances are often switched on or off on the secondary side. The transformer power supplies are permanently connected to the mains. Devices with these features must be disconnected from the mains after operation by unplugging the mains plug or by a switchable multiple socket strip or power consumption is learnt-in and is also disconnected (up to 200mA).

## **Time-controlled roller blind controls directly mounted at the windows?**

These roller blind controls receive a continuous quiescent current and should not be operated downstream of a mains disconnection relay for this reason. If disconnection is not possible from the room electrical circuit, the roller blind controls must be replaced by roller blind switches.

## **Electronic impulse switches downstream of a mains disconnection relay?**

We recommend the electronic impulse switches ESR12NP which can also connect the FR12 without an additional base load.

Electromechanical impulse switches need to be pressed a little longer until the FR12 and the lighting circuit switch on.

## **Fluorescent lamps or compressed fluorescent lamps (energy saving lamps) downstream of a mains disconnection relay?**

Fluorescent lamps always require a base load which must be connected in parallel to the lamp.