



Switching and Control Professionals

| | |
|---|-----|
| Selection table switching relays, control relays and coupling relays | C0 |
| Switching relay ER12DX | C1 |
| Switching relay ER12 | C2 |
| Impulse switch with integrated relay function ESR12NP | C3 |
| Digital settable multifunction impulse switch with integrated relay function ESR12DDX | C4 |
| Switching and control relays ER12 | C5 |
| Coupling relays KR09 | C6 |
| Switching relay ER61-UC and Impulse switch with integrated relay function ESR61NP | C7 |
| Multifunction impulse switch with integrated relay function ESR61M | C8 |
| Isolating relay ETR61NP with window contact FK | C9 |
| Technical data | C10 |

Selection Table

Switching Relays, Control Relays and Coupling Relays

Switching and control professionals

Professional hybrid relays combine the advantages of nonwearing electronic control with high switching capacity of special relays. We also use mainly bistable relays. Thus preventing coil power loss even in the on mode. This increases energy efficiency and reduces heating in the switch cabinet.

| Page | | C1 | C2 | C2 | C3 | C4 | C5 | C5 | C6 | C7 | C7 | C8 | C9 |
|---|---|-----------------|-----------------|-----------------|-------------------|--------------------------------------|-----------------|-----------------|----------------------------|-----------------|--------------------|--------------------------------------|--------------|
|  | pictograms | ER12DX-UC | ER12-200-UC | ER12-110-UC | ESR12NP-230V+UC | ESR12DDX-UC | ER12-001-UC | ER12-002-UC | KR09-12 V UC, 24V UC, 230V | ER61-UC | ESR61NP-230V+UC | ESR61M-UC | ETR61NP-230V |
| Modular device for mounting on DIN rail EN 60715 TH35, number of modules 18 mm each | | 1 | 1 | 1 | 1 | 1 | 1 | 1 | ½ | | | | |
| Built-in device for installation (e.g. flush-mounting box) | | | | | | | | | | ■ | ■ | ■ | ■ |
| Number NO contacts or changeover contact (W) potential free (not potential free) | | 1 | 2 | 1 | (1) | 1+1 ²⁾ 2 ²⁾ | 1W | 2W | 1 | 1W | (1) | 1+1 ²⁾ 2 ²⁾ | (1) |
| Number NC contacts potential free | | | | 1 | | 1-2 ²⁾ | | | | | | 1-2 ²⁾ | |
| Zero passage switching |  | ■ ⁷⁾ | | | ■ | | | | | | ■ | | |
| Switching capacity 16A/250V AC | | ■ | ■ | ■ | ■ | ■ | ■ | ■ | | ■ | | | |
| Switching capacity 10A/250V AC | | | | | | | | | 6A | | ■ | ■ | ■ |
| Incandescent lamp load W |  | 2000 | 2000 | 2000 | 2300 | 2000 | 2000 | 2000 | 500 | 2000 | 2000 | 2000 | 2000 |
| Bistable relay(s) as relay contact(s) |  | ■ ⁵⁾ | ■ ⁵⁾ | ■ ⁵⁾ | | ■ ⁶⁾ | ■ ⁵⁾ | ■ ⁵⁾ | | ■ ⁵⁾ | ■ ⁶⁾ | ■ ⁵⁾ | |
| Switchable between the functions for impulse switches and switching relays | | | | | ■ | ■ | | | | | ■ | ■ | |
| Universal control voltage |  | ■ | ■ | ■ | ■ | ■ | ■ | ■ | | ■ | ■ | ■ | |
| (additional) control voltage 230V | | | | | (■) | | | | | | ■ | | |
| Supply voltage same as control voltage | | | | | | ■ | | | | | | | |
| Supply voltage 230V | | | | | ■ ³⁾ | | | | | | ■ | | |
| No standby loss |  | ■ | ■ | ■ | | | ■ | ■ | ■ | ■ | | ■ | |
| Low standby loss |  | | | | ■ | ■ | | | | | ■ | | ■ |
| Glow lamp current (mA) at the control input 230V |  | | | | 150 ¹⁾ | 5 | | | | | 50 ¹⁾⁴⁾ | | |

¹⁾ Glow lamp current independent from the ignition voltage.

²⁾ Depends on the set function.

³⁾ If the control voltage is 230V, but the phase conductor is different from the 230V supply voltage, the universal voltage control input must be used.

⁴⁾ At the control input .

⁵⁾ The relay contact can be open or closed when putting into operation. It will be synchronised at first operation.

⁶⁾ The switched consumer may not be connected to the mains before the short automatic synchronisation after installation has terminated.

⁷⁾ Patented duplex technology: When switching 230V/50Hz the contact switching takes place in the zero passage when L is connected to (L) and N to (N). The standby loss is then 0.1 Watt.

ER12DX-UC

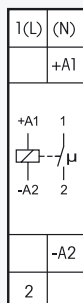

1 NO contact potential free 16 A/250 V AC, incandescent lamp load up to 2000 W. No standby loss.

Modular device for DIN-EN 60715 TH35 rail mounting.
1 module = 18 mm wide, 58 mm deep.

State-of-the-art hybrid technology combines advantages of nonwearing electronic control with high capacity of special relays.

With the patented Eltako Duplex technology (DX) the normally potential-free contacts can still switch in zero passage when switching 230 V AC 50 Hz and therefore drastically reduce wear. Simply connect the neutral conductor to the terminal (N) and L to 1 (L) for this. This gives an standby consumption of only 0.1 Watt.

If the contact is used for controlling switching devices which do not perform zero passage switching themselves, (N) should not be connected because the additional closing delay otherwise causes the opposite effect.

Universal control voltage 8 to 230 V UC.

Very low switching noise.

Contact position indicator with LED.

Same terminal connection as electromechanical switching relay R12-100-.

By using a bistable relay coil power loss and heating is avoided even in the on mode.

The relay contact can be open or closed when putting into operation. It will be synchronised at first operation.

This relay is not suitable to feed back the switching voltage signal of a dimmer switch. Use only relays ESR12DDX-UC, ESR12NP-230V+UC or ESR61NP-230V+UC for this purpose.

This electronic switchgear represents the latest generation:

The electronics does not have an internal power supply and therefore no standby loss.

The microcontroller is activated when the control contact closes. This switches the bistable relay to the correct direction. The bistable relay switches back either when the control contact opens or when the control voltage falls.

Typical connection

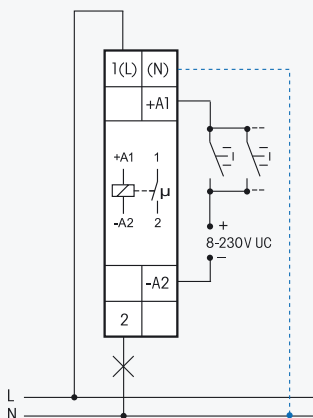

If N is connected, the zero passage switching is active.

Switching Relay ER12

C2

ER12-200-UC

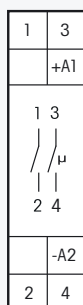

2 NO contacts potential free 16A/250V AC, incandescent lamp load up to 2000W. No standby loss.

Modular device for DIN-EN 60715 TH35 rail mounting. 1 module = 18mm wide, 58mm deep. State-of-the-art hybrid technology combines advantages of nonwearing electronic control with high capacity of special relays.

Universal control voltage 8 to 230V UC.

Very low switching noise.

Contact position indicator with LED.

Maximum current across both contacts 20A for 230V.

Same terminal connection as electromechanical switching relay R12-200-.

By using a bistable relay coil power loss and heating is avoided even in the on mode.

The relay contact can be open or closed when putting into operation. It will be synchronised at first operation.

This relay is not suitable to feed back the switching voltage signal of a dimmer switch. Use only relays ESR12DDX-UC, ESR12NP-230V+UC or ESR61NP-230V+UC for this purpose.

This electronic switchgear represents the latest generation:

The electronics does not have an internal power supply and therefore no standby loss.

The microcontroller is activated when the control contact closes. This switches the bistable relay to the correct direction. The bistable relay switches back either when the control contact opens or when the control voltage falls.

Technical data page C10. Housing for operating instructions GBA12 page Z5.

ER12-200-UC

2 NO 16A

EAN 4010312205433

39,40 €/pc.

ER12-110-UC

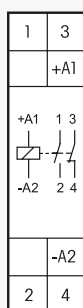

1 NO + 1 NC contact potential free 16A/250V AC, incandescent lamp load up to 2000W. No standby loss.

Modular device for DIN-EN 60715 TH35 rail mounting. 1 module = 18mm wide, 58mm deep. State-of-the-art hybrid technology combines advantages of nonwearing electronic control with high capacity of special relays.

Universal control voltage 8 to 230V UC.

Very low switching noise.

Contact position indicator with LED.

Same terminal connection as electromechanical switching relay R12-110-.

By using a bistable relay coil power loss and heating is avoided even in the on mode.

The relay contact can be open or closed when putting into operation. It will be synchronised at first operation.

This relay is not suitable to feed back the switching voltage signal of a dimmer switch. Use only relays ESR12DDX-UC, ESR12NP-230V+UC or ESR61NP-230V+UC for this purpose.

This electronic switchgear represents the latest generation:

The electronics does not have an internal power supply and therefore no standby loss.

The microcontroller is activated when the control contact closes. This switches the bistable relay to the correct direction. The bistable relay switches back either when the control contact opens or when the control voltage falls.

Technical data page C10. Housing for operating instructions GBA12 page Z5.

ER12-110-UC

1 NO + 1 NC 16 A

EAN 4010312205440

39,40 €/pc.

Recommended retail prices excluding VAT.

ESR12NP-230V+UC

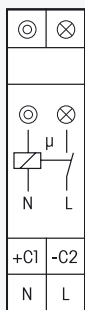

1 NO contact not potential free 16A/250V AC, incandescent lamp load up to 2300W. Off delay impulse switch with switch-off early warning and push-button permanent light switchable. Standby loss 0.5 watt only.

Modular device for DIN-EN 60715 TH35 rail mounting. 1 module = 18mm wide, 58mm deep.

Zero passage switching to protect contacts and lamps. This prolongs in particular the lifetime of energy saving lamps.

State-of-the-art hybrid technology combines advantages of nonwearing electronic control with high capacity of special relays.

Control voltage 230V. In addition electrically isolated universal voltage from 8 to 230V UC. Supply voltage and switching voltage 230V.

Very low switching noise. If the function ESV is set, definitely variable off-delay time RV from 2 to 120 minutes, settable by minute scale.

Contact position indication with two LEDs. This starts blinking in case of a blocked push-button (not if the function ER is set).

Glow lamp current up to 150mA only at the control input 230V independent from ignition voltage (not if the function ER is set).

Relays with suitable functions to feed back the switching voltage signal of a dimmer switch.

In case of a power failure the system is disconnected in a preset sequence.

The functions ES, ESV or ER are selectable **by means of a rotary switch**.

ES = Impulse switch

ER = Switching relay

ESV = Impulse switch with off delay. The impulse switch automatically disconnects after the set delay is timed out if a manual OFF command has not been given. Infinitely variable time range up to 120 minutes.

ESV = If switch-off early warning \sqcup is set the stairwell lighting starts flickering approximately + \sqcup 30 seconds before timeout at repeated shorter time intervals. During this process reset is possible.

ESV = If push-button permanent light \odot is set permanent light can be switched on by + \odot pressing longer than 1 sec. This switches off automatically after 2 hours or by an operation longer than 2 seconds.

ESV If both switch-off early warning function and permanent light by push-button $\sqcup \odot$ are + $\sqcup \odot$ set, the switch-off early warning function is activated before switching off the permanent light.

This electronic impulse switch does not need a base load for switching lights in rooms which are monitored by a FR12-230V mains disconnection relay.

Function rotary switches

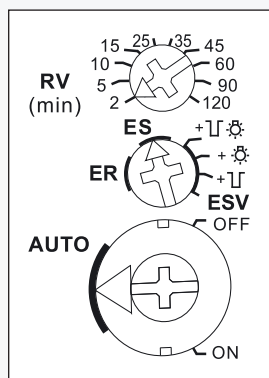

Standard setting ex factory.

\sqcup = switch-off early warning

\odot = push-button permanent light

$\sqcup \odot$ = switch-off early warning and push-button permanent light

Typical connection

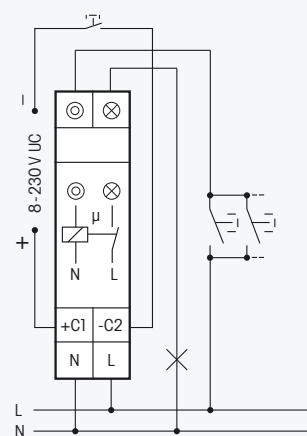

Technical data page C10. Housing for operating instructions GBA12 page Z5.

ESR12NP-230V+UC

1 NO 16A

EAN 4010312107928

37,20 €/pc.

Recommended retail prices excluding VAT.

Digital settable Multifunction Impulse Switch with integrated relay function ESR12DDX

ESR12DDX-UC



1+1 NO contacts potential free 16A/250V AC.

Incandescent lamp load up to 2000W. Standby loss 0.03 - 0.4 watt only.

Modular device for DIN-EN 60715 TH35 rail mounting. 1 module = 18mm wide, 58mm deep. **With the patented Eltako Duplex technology (DX) the normally potential-free contacts can still switch in zero passage when switching 230V AC 50Hz and therefore drastically reduce wear. Simply connect the neutral conductor to the terminal (N) and L to 1(L) and/or 3(L) for this. This results in an additional standby consumption of only 0.1 Watt.**

Universal control voltage 8 to 230V UC. Supply voltage is same as the control voltage.

The functions are set with the keys MODE and SET as described in the operating instructions. They are indicated on the display and can be blocked if required.

The accrued switch-on time is continuously displayed. First in hours (h), then in months (m) with 1 digit after the decimal point.

By using bistable relays coil power loss and heating is avoided even in the on mode.

The switched consumer may not be connected to the mains before the short automatic synchronisation after installation has terminated.

Only impulse switch functions: After a power failure the system is disconnected in a definite sequence or the switch position is kept depending on the setting (then + on the display next to function abbreviations). Settings under RSM in the menu guidance. Furthermore, when using these functions, with the keys MODE and SET, the control inputs A1 and A3 can be defined as central control inputs.

ZA1 = 'central off' with A1, local with A3; **ZE1** = 'central on' with A1, local with A3;

Z00 = no central control. 'Central on' with A1, 'central off' with A3. No local control refer to function RS.

Relays with suitable functions to feed back the switching voltage signal of a dimmer switch.

From 110V control voltage and in the settings 2S, WS, SS and GS glow lamp current up to 5mA, dependent on the ignition voltage.

With the keys MODE and SET you can select amongst 18 functions:

OFF = Permanent OFF

2xS = 2-fold impulse switch with 1 NO contact each, control inputs A1 and A3

2S = Impulse switch with 2 NO contacts

WS = Impulse switch with 1 NO contact and 1 NC contact

SS1 = Impulse multi circuit switch 1+1 NO contacts for switching sequence
0 - contact 1 (1-2) - contact 2 (3-4) - contacts 1 + 2

SS2 = Impulse multi circuit switch 1+1 NO contacts for switching sequence
0 - contact 1 - contacts 1 + 2 - contact 2

SS3 = Impulse multi circuit switch 1+1 NO contacts for switching sequence
0 - contact 1 - contacts 1 + 2

GS = Impulse group switch 1+1 NO contacts for switching sequence
0 - contact 1 - 0 - contact 2

RS = Switch with 2 NO contacts, with A1 = set control input and A3 = reset control input

2xR = 2-fold switching relay with 1 NO contact each, control inputs A1 and A3

2R = Switching relay with 2 NO contacts

WR = Switching relay with 1 NO contact and 1 NC contact

RR = Switching relay (closed-circuit current relay) with 2 NC contacts

EAW = Impulse relay for fleeting NO contact and fleeting NC contact with 1+1 NO contacts, wiping time 1 sec each

EW = Impulse relay for fleeting NO contact with 1 NO contact and 1 NC contact, wiping time 1 sec

AW = Impulse relay fleeting NC contact with 1 NO contact and 1 NC contact, wiping time 1 sec

GR = Group relay 1+1 NO contacts (relay with alternating closing contacts)

ON = Permanent ON

The control inputs A1 and A3 have the same functions except for 2xS, 2xR and RS, if not used as central control inputs.

After setting the required function, the function can be blocked.

An arrow on the right of the abbreviation indicates the blocking status.

Typical connection

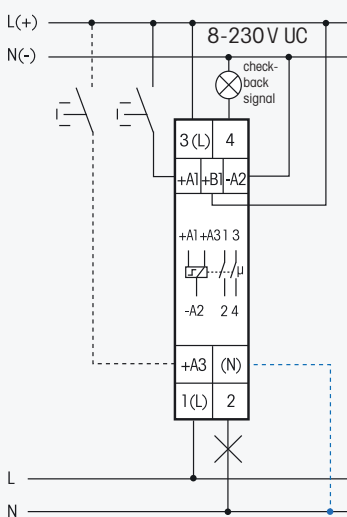

If N is connected, the zero passage switching is active.

Technical data page C10. Housing for operating instructions GBA12 page Z5.

ESR12DDX-UC

1+1 NO 16A

EAN 4010312108093

51,00 €/pc.

Recommended retail prices excluding VAT.

ER12-001-UC

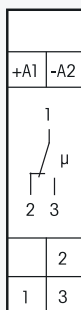
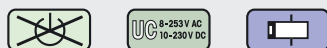

1 change over contact potential free 16A/250V AC, incandescent lamp load up to 2000W. No standby loss.

Modular device for DIN-EN 60715 TH35 rail mounting.
1 module = 18mm wide, 58mm deep.

State-of-the-art hybrid technology combines advantages of nonwearing electronic control with high capacity of special relays. Universal control voltage 8 to 230V UC.

Low control power demand, therefore substantially less heat is generated.

Integrated free-wheeling anti-surge diode (A1 = +, A2 = -).

Safe disconnection to VDE 0106, Part 101; therefore, these devices can also be used as coupling relays.

By using a bistable relay coil power loss and heating is avoided even in the on mode.

The relay contact can be open or closed when putting into operation. It will be synchronised at first operation.

This relay is not suitable to feed back the switching voltage signal of a dimmer switch. Use only relays ESR12DDX-UC, ESR12NP-230V+UC or ESR61NP-230V+UC for this purpose.

This electronic switchgear represents the latest generation:

The electronics does not have an internal power supply and therefore no standby loss.

The microcontroller is activated when the control contact closes. This switches the bistable relay to the correct direction. The bistable relay switches back either when the control contact opens or when the control voltage falls.

Technical data page C10.
Housing for operating instructions
GBA12 page Z5.

ER12-001-UC

1 CO 16 A

EAN 4010312205365

38,10 €/pc.

ER12-002-UC

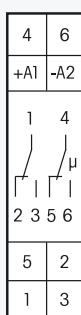
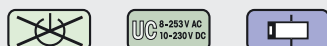

2 change over contacts potential free 16A/250V AC, incandescent lamp load up to 2000W. No standby loss.

Modular device for DIN-EN 60715 TH35 rail mounting. 1 module = 18mm wide, 58mm deep.

State-of-the-art hybrid technology combines advantages of nonwearing electronic control with high capacity of special relays.

Low switching noise. Contact position indicator with LED.

Integrated free-wheeling anti-surge diode (A1 = +, A2 = -).

By using a bistable relay coil power loss and heating is avoided even in the on mode.

The relay contact can be open or closed when putting into operation. It will be synchronised at first operation.

This relay is not suitable to feed back the switching voltage signal of a dimmer switch. Use only relays ESR12DDX-UC, ESR12NP-230V+UC or ESR61NP-230V+UC for this purpose.

This electronic switchgear represents the latest generation:

The electronics does not have an internal power supply and therefore no standby loss.

The microcontroller is activated when the control contact closes. This switches the bistable relay to the correct direction. The bistable relay switches back either when the control contact opens or when the control voltage falls.

Technical data page C10. Housing for operating instructions GBA12 page Z5.

ER12-002-UC

2 CO 16 A

EAN 4010312205372

44,50 €/pc.

Recommended retail prices excluding VAT.

Coupling Relays KR09

C6

KR09-12V UC

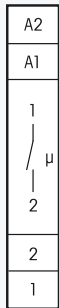

1 NO contact potential free 6 A/250V AC, incandescent lamp load up to 500W. No standby loss.

Modular device for DIN-EN 60715 TH35 rail mounting.
1/2 module = 9mm wide, 55mm deep.

State-of-the-art hybrid technology combines advantages of nonwearing electronic control with high capacity of special relays.

Control voltages 12V UC.

Contact position indicator with LED. Control power demand 0.2W only.

Safe disconnection to VDE 0106, Part 101; therefore, these devices can also be used as coupling relays.

Technical data page C10. Housing for operating instructions GBA12 page Z5.

| | | | |
|--------------------|---------|-------------------|--------------------|
| KR09-12V UC | 1 NO 6A | EAN 4010312203415 | 32,30 €/pc. |
|--------------------|---------|-------------------|--------------------|

KR09-24V UC

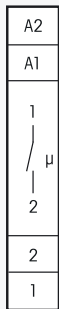

1 NO contact potential free 6 A/250V AC, incandescent lamp load up to 500W. No standby loss.

Modular device for DIN-EN 60715 TH35 rail mounting.
1/2 module = 9mm wide, 55mm deep.

State-of-the-art hybrid technology combines advantages of nonwearing electronic control with high capacity of special relays.

Control voltages 24V UC.

Contact position indicator with LED. Control power demand 0.2W only.

Safe disconnection to VDE 0106, Part 101; therefore, these devices can also be used as coupling relays.

Technical data page C10. Housing for operating instructions GBA12 page Z5.

| | | | |
|--------------------|---------|-------------------|--------------------|
| KR09-24V UC | 1 NO 6A | EAN 4010312203385 | 32,30 €/pc. |
|--------------------|---------|-------------------|--------------------|

KR09-230V

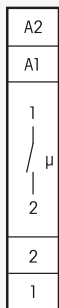

1 NO contact potential free 6 A/250V AC, incandescent lamp load up to 500W. No standby loss.

Modular device for DIN-EN 60715 TH35 rail mounting.
1/2 module = 9mm wide, 55mm deep.

State-of-the-art hybrid technology combines advantages of nonwearing electronic control with high capacity of special relays.

Control voltages 230V.

Contact position indicator with LED. Control power demand 0.2W only.

Safe disconnection to VDE 0106, Part 101; therefore, these devices can also be used as coupling relays.

Technical data page C10. Housing for operating instructions GBA12 page Z5.

| | | | |
|------------------|---------|-------------------|--------------------|
| KR09-230V | 1 NO 6A | EAN 4010312203378 | 32,30 €/pc. |
|------------------|---------|-------------------|--------------------|

Recommended retail prices excluding VAT.

ER61-UC

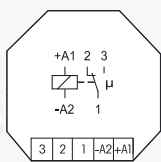

1 change over contact potential free 16 A/250 V AC, incandescent lamp load up to 2000W. No standby loss.

For installation. 45 mm long, 55 mm wide, 18 mm deep.

State-of-the-art hybrid technology combines advantages of nonwearing electronic control with high capacity of special relays. Universal control voltage 8 to 230V UC. Low switching noise.

By using a bistable relay coil power loss and heating is avoided even in the on mode.

The relay contact can be open or closed when putting into operation. It will be synchronised at first operation.

This relay is not suitable to feed back the switching voltage signal of a dimmer switch. Use only relays ESR12DDX-UC, ESR12NP-230V+UC or ESR61NP-230V+UC for this purpose.

This electronic switchgear represents the latest generation:

The electronics does not have an internal power supply and therefore no standby loss.

The microcontroller is activated when the control contact closes. This switches the bistable relay to the correct direction. The bistable relay switches back either when the control contact opens or when the control voltage falls.

Typical connection

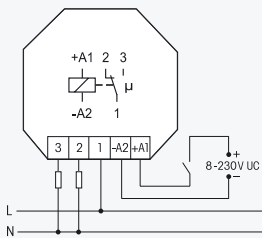

Technical data page C10.
Short-stroke pushbuttons page Z1-Z3.

ER61-UC

1 CO 16A

EAN 4010312205358

35,40 €/pc.

ESR61NP-230V+UC

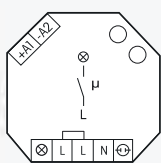

1 NO contact not potential free 10 A/250 V AC, incandescent lamp load up to 2000W. Off delay impulse switch with switch-off early warning and push-button permanent light switchable. Standby loss 0.7 watt only.

For installation. 45 mm long, 55 mm wide, 18 mm deep.

Zero passage switching to protect contacts and lamps. This prolongs in particular the lifetime of energy saving lamps.

State-of-the-art hybrid technology combines advantages of nonwearing electronic control with high capacity of special relays.

By using a bistable relay coil power loss and heating is avoided even in the on mode.

The switched consumer may not be connected to the mains before the short automatic synchronisation after installation has terminated.

Control voltage 230V. In addition electrically isolated universal control voltage from 8 to 230V UC. Supply voltage and switching voltage 230V. Very low switching noise. Variable time range up to 120 minutes in the function **ESV**. At the control input push-buttons with a glow lamp current up to 50mA can be connected. In case of a power failure the system is disconnected in a pre-set sequence.

If the timing period is set to minimum in the function **ESV**, the release delay is switched off.

The standard impulse switch function **ES** is then set. The function **ER** is selectable. If the function **ER** is selected a glow lamp current is not permitted. Only the control input A1- A2 should be used.

When set to the function ER this device is suitable to feed back the switching voltage signal of a dimmer switch.

If switch-off early warning function is switched on, the light starts flickering approx. 30 seconds before time-out. This is repeated three times at decreasing time intervals.

If the permanent light function is switched on, the function can be activated by pressing the push-button for longer than 1 second. This function switches off automatically after 2 hours or by pressing the push-button for longer than 2 seconds.

If both switch-off early warning function and permanent light by push-button are set, the switch-off early warning function is activated before switching off the permanent light.

Function rotary switches

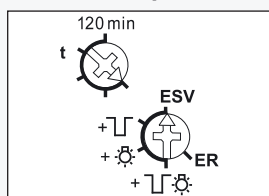

Standard setting ex factory.

Typical connection

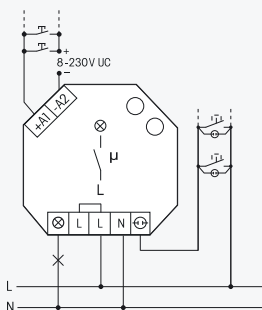

Side view



Technical data page C10.
Short-stroke pushbuttons page Z1-Z3.

ESR61NP-230V+UC

1 NO 10A

EAN 4010312107911

39,20 €/pc.

Multifunction Impulse Switch with integrated relay function ESR61M

ESR61M-UC

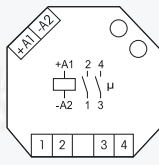

**1+1 NO contacts potential free 10A/250V AC.
Incandescent lamp load up to 2000W. No standby loss.**

For installation. 45 mm long, 55 mm wide, **32 mm deep.**

State-of-the-art hybrid technology combines advantages of nonwearing electronic control with high capacity of special relays.

Universal control voltage 8 to 230V UC.

No permanent power supply necessary, therefore no standby loss.

By using bistable relays coil power loss and heating is avoided even in the on mode.

The switched consumer may not be connected to the mains before the short automatic synchronisation after installation has terminated.

The functions of the second rotary switch are preselected using the rotary switch ES/ER. The setting ER selects the function in brackets. 10 different functions are selectable.

- 2S** = Impulse switch with 2 NO contacts
- (2R)** = Switching relay with 2 NO contacts
- WS** = Impulse switch with 1 NO contact and 1 NC contact
- (WR)** = Switching relay with 1 NO contact and 1 NC contact
- SS1** = Impulse multi circuit switch 1+1 NO contacts for switching sequence
0 - contact 1 (1-2) - contact 2 (3-4) - contacts 1 + 2
- (RR)** = Switching relay (closed-circuit current relay) with 2 NC contacts
- SS2** = Impulse multi circuit switch 1+1 NO contacts for switching sequence
0 - contact 1 - contacts 1 + 2 - contact 2
- (EW)** = Impulse relay for fleeting NO contact with 1 NO contact and 1 NC contact, wiping time 1 sec
- GS** = Impulse group switch 1+1 NO contacts for switching sequence
0 - contact 1 - 0 - contact 2
- (GR)** = Group relay 1+1 NO contacts (relay with alternating closing contacts)

This relay is not suitable to feed back the switching voltage signal of a dimmer switch. Use only relays ESR12DDX-UC, ESR12NP-230V+UC or ESR61NP-230V+UC for this purpose.

This electronic switchgear represents the latest generation:

The electronics does not have an internal power supply and therefore no power is consumed in any contact position. A control current flows only during a short control impulse of 0.2 seconds. This activates the microcontroller, reads the last switching state from the non-voltage memory, switches the bistable relay to its opposite state accordingly and rewrites the new switching state to memory.

C8

Function rotary switches

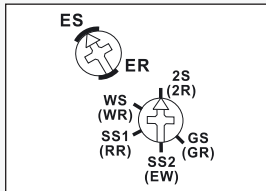

Standard setting ex factory.

Typical connection

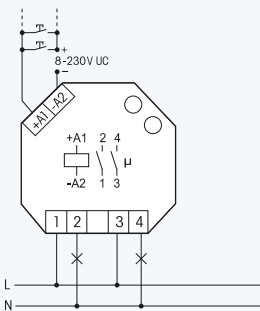

Side view

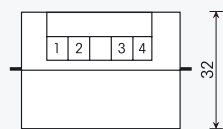

Technical data page C10. Short-stroke pushbuttons page Z1-Z3.

ESR61M-UC

1 + 1 NO 10A

EAN 4010312108079

50,80 €/pc.

Recommended retail prices excluding VAT.

ETR61NP-230V+FK

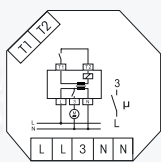

1 NO contact not potential free 10A/250V AC. With window contact. Standby loss 0.5 watt only.

For installation. 45 mm long, 55 mm wide, 18 mm deep.

State-of-the-art hybrid technology combines advantages of nonwearing electronic control with high capacity of special relays.

Control input with internally produced low voltage 24 V DC. With an isolating transformer electrically isolated from power supply and make contact (PELV).

Therefore no external low voltage power supply necessary.

With 2 L terminals and 2 N terminals for an easy and quick installation.

The enclosed window contact consists of a Reed relay with terminals and a solenoid. The NC contact opens when the solenoid approaches closer than 25 mm. The disconnection relay ETR61NP is connected to terminals T1 and T2. Power supply to the extractor only cuts in when the window is open. ETR61NP can be wired in the flush mounted socket behind the socket for the extractor.

Power supply 230V.

Mounting the window contact FK:

Lever out the inserts at the narrow end of the housing. Wire up the Reed relay and cut out the cable entry on the housing. Affix the two housings in parallel maximum 15mm apart and also screw if necessary. In the longitudinal direction the solenoid may be twisted in any direction compared to the Reed relay.

Typical connection

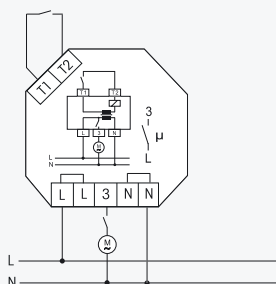

The power supply of an extractor hood is connected by a window contact (NO if window open) so it can be switched on only if the window is open.

Window contact FK



Reed relay and solenoid each
54 x 12 x 10 mm

Technical data page C10.

ETR61NP-230V

1 NO 10A

EAN 4010312205488

49,30 €/pc.

FK

Window contact FK



Reed relay and solenoid each
54 x 12 x 10 mm

Window contact

The window contact as described above is also supplied as individual (accessory) item.

Reed relay with 1 NO contact, switching capacity 5 W or VA. Switching voltage max. 175 V UC.

FK

window contact

EAN 4010312903001

20,20 €/pc.

Recommended retail prices excluding VAT.

Technical Data Electronic Switching Relays, Control Relays and Coupling Relays

C10

| Contacts | ESR12NP-230V+UC ^{a)} | ESR12DDX-UC ^{b)} , ER12DX-UC ^{a)} , ER12-200-UC ^{a)} , ER12-110-UC ^{a)} , ER12-001-UC ^{a)} , ER12-002-UC ^{a)} , ER61-UC ^{a)} | ESR61NP-230V+UC ^{b)} , ESR61M-UC ^{a)} , ETR61NP-230V | KR09 -12V UC, -24V UC, -230V |
|---|---|---|--|------------------------------|
| Contact material/contact gap | AgSnO ₂ / 0,5 mm | | | |
| Spacing of control connections/contact | 3 mm | 6 mm, ER61: 3 mm | 6 mm | 6 mm |
| Spacing of control connections C1-C2 or A1-A2/contact | 6 mm | 6 mm | ESR61NP+M: 6 mm | – |
| Test voltage contact/contact | – | ESR12DDX: 4000V ER12-200/110: 2000V | ESR61M: 2000V | – |
| Test voltage control connections/contact Test voltage C1-C2 or A1-A2/contact | 2000V 4000V | 4000V, ER61: 2000V – | 2000V ESR61NP+M+ETR61NP: 4000V | 4000V – |
| Rated switching capacity | 16 A/250V AC | 16 A/250V AC | 10 A/250V AC | 6 A/250V AC |
| Incandescent lamp and halogen lamp load ¹⁾ 230V | 2300 W | 2000 W | 2000 W | 500 W |
| Fluorescent lamp load with KVG* in lead-lag circuit or non compensated | 1000 VA | 1000 VA | 1000 VA | 600 VA |
| Fluorescent lamp load with KVG* shunt-compensated or with EVG* | 500 VA | 500 VA | 500 VA | 300 VA |
| Compact fluorescent lamps with EVG* and energy saving lamps ESL | 15x7 W 10x20 W | 1 on ≤ 70A/ 10ms ^{2) 3)} When using DX types: 15x7W, 10x20W ³⁾ | 1 on ≤ 70A/10ms ²⁾ ESR61NP: 15x7 W, 10x20W | 52 W |
| Max. switching current DCI: 12V/24V DC | – | 8 A | not ESR: 8A | 6 A |
| Life at rated load, cos φ = 1 or for incandescent lamps 1000W at 100/h | > 10 ⁵ | > 10 ⁵ | > 10 ⁵ | > 10 ⁵ |
| Life at rated load, cos φ = 0.6 at 100/h | > 4 x 10 ⁴ | > 4 x 10 ⁴ | > 4 x 10 ⁴ | – |
| Max. operating cycles | 10 ³ /h | 10 ³ /h | 10 ³ /h, | 10 ⁴ /h |
| Contact position indication | LED (not series 61) | | | |
| Maximum conductor cross-section | series 12: 6 mm ² (3-fold terminal 4 mm ²), series 61: 4 mm ² | | | |
| Two conductors of same cross-section | series 12: 2.5 mm ² (3-fold terminal 1.5 mm ²), series 61: 1.5 mm ² | | | |
| Screw head | series 12: slotted/crosshead, pozidriv, series 61: slotted/crosshead | | | |
| Type of enclosure/terminals | series 12: IP50/IP20, series 61: IP30/IP20 | | | |
| Electronics | | | | |
| Time on | 100 % | 100 % | 100 % | 100 % |
| Max./min. temperature at mounting location | +50°C/-20°C | +50°C/-20°C | +50°C/-20°C | +50°C/-20°C |
| Stand by loss (active power) | 0.5 W | –; ESR12DDX: 0.4 W | –; ESR61NP: 0.7 W, ETR61NP: 0.5 W | – |
| Control current 230V control input local ±20% | 10 mA | – | 10 mA, ESR61M: – | – |
| Control current universal control voltage all control voltages mA ±20% | – | 4 (not ESR12DDX) | ER61: 2, ESR61M: 4 | – |
| Control current at 8/12/24/230V (<10s) mA ±20% | 2/4/9/5 (100) | only ESR12DDX: 2/3/7/3 (50) mA | only ESR61NP: 2/4/9/5 (100) only ETR61NP: 10mA/24V DC | –/15/ 10/11 |
| Max. parallel capacitance (approx. length) of control lead at 230V AC | ES: 0,3 μF (1000 m) ER: 3 nF (10 m) C1-C2: 15 nF (50 m) | 0,06 μF (200 m) ESR12DDX: 0,3 μF (1000 m) | 0,06 μF (200 m) | 0.06 μF (200 m) |

* EVG = electronic ballast units; KVG = conventional ballast units

^{a)} Bistable relay as relay contact. The relay contact can be open or closed when putting into operation. It will be synchronised at first operation.

^{b)} Bistable relay as relay contact. The switched consumer may not be connected to the mains before the short automatic synchronisation after installation has terminated.

¹⁾ For lamps with 150W max.

²⁾ A 40-fold inrush current must be expected for electronic ballast devices. For steady loads of 1200W or 600W use the currentlimiting relay SBR12 or SBR61. Product group G, page G4.

³⁾ When using DX types close attention must be paid that zero passage switching is activated!