



**The Silent Revolution**









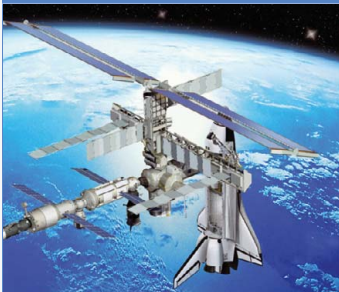

Selection table electronic impulse switches	A0
Impulse switch <a href="#">ES12DX</a>	A1
Impulse switch <a href="#">ES12-200</a>	A2
Impulse switch <a href="#">ES12-110</a>	A3
Impulse switch with integrated relay function <a href="#">ESR12NP</a>	A4
Digital settable multifunction impulse switch with integrated relay function <a href="#">ESR12DDX</a>	A5
Impulse switch with potential free contacts <a href="#">ES12Z</a> , also for central control	A6
4-fold impulse switch with integrated relay function <a href="#">ESR12Z-4DX-UC</a> , also for central control and group control	A7
Impulse switch <a href="#">ES61</a>	A8
Impulse switch with integrated relay function <a href="#">ESR61NP</a>	A9
Multifunction impulse switch with integrated relay function <a href="#">ESR61M</a>	A10
Impulse switch for installation in lighting fittings <a href="#">ES75</a>	A11
Technical data	A12

# Selection Table Electronic Impulse Switches

AO

## The silent revolution

Without attracting particular attention by switching noise, the importance of electronic impulse switches with all their variants compared to conventional mechanical versions is growing steadily. They offer a highly reduced switching noise and further attractive advantages, such as multifunction, central control, zero passage switching for AC voltage, minimized control power demand and universal control voltage.

Page	A1	A2	A3	A4	A5	A6	A6	A7	A8	A9	A10	A11	
	<b>pictograms</b>	ES12DX-UC	ES12-200-8..230V UC	ES12-110-8..230V UC	ESR12NP-230V+UC	ESR12DDX	ES12Z-200-8..230V UC	ES12Z-110-8..230V UC	ESR12Z-4DX-UC	ES61-8..230V UC	ESR61NP-230V+UC	ESR61M-UC	ES75-12..24V UC
Modular device for mounting on DIN rail EN 60715 TH35, number of modules 18 mm each	1	1	1	1	1	1	1	2					
Built-in device for installation (e.g. flush-mounting box)									■	■	■	■	
Number NO contacts (not potential free)	1	2	1	(1)	1+1 <sup>3)</sup> 2 <sup>3)</sup>	2	1	4x1	1	(1)	1+1 <sup>3)</sup> 2 <sup>3)</sup>	(1)	
Number NC contacts potential free			1		1-2 <sup>3)</sup>		1				1-2 <sup>3)</sup>		
Zero passage switching		■ <sup>10)</sup>			■			■ <sup>10)</sup>		■			
Switching capacity 16A/250V AC		■	■	■	■	■	■	■					
Switching capacity 10A/250V AC									■	■	■	■	
Incandescent lamp load W		2000	2000	2000	3600	2000	2000	2000	2000	2000	2000	500	
Bistable relay(s) as relay contact(s)		■ <sup>8)</sup>	■ <sup>8)</sup>	■ <sup>8)</sup>		■ <sup>9)</sup>	■ <sup>9)</sup>	■ <sup>9)</sup>	■ <sup>9)</sup>	■ <sup>8)</sup>	■ <sup>9)</sup>	■ <sup>8)</sup>	
Universal control voltage		■	■	■	■	■	■	■	■	■	■	■	
Additional control voltage 230V		■ <sup>5)</sup>	■ <sup>5)</sup>	■ <sup>5)</sup>	■ <sup>6)</sup>				■ <sup>5)</sup>	■ <sup>6)</sup>			
Control voltage 12 to 24V UC												■	
Supply voltage same as control voltage					■	■	■	■					
Supply voltage 230V				■ <sup>6)</sup>						■ <sup>6)</sup>		■	
No standby loss		■ <sup>10)</sup>	■	■		■ <sup>10)</sup>			■		■		
Low standby loss					■	■ <sup>10)</sup>	■	■	■ <sup>10)</sup>	■		■	
Glow lamp current (mA) at the control input 230V		5 <sup>1)7)</sup>	5 <sup>1)7)</sup>	5 <sup>1)7)</sup>	150 <sup>2)</sup>				5 <sup>1)7)</sup>	50 <sup>2)7)</sup>			
Glow lamp current (mA) at the control input for universal voltage						50 <sup>1)</sup>	50 <sup>1)4)</sup>	50 <sup>1)4)</sup>					
Off delay, switch-off early warning function and permanent light by push-button can be switched on					■					■			
Multi circuit switch						■ <sup>3)</sup>					■ <sup>3)</sup>		
Group switch						■ <sup>3)</sup>					■ <sup>3)</sup>		
Central control electrically isolated from the local control							■	■	■				

<sup>1)</sup> Applies to glow lamps with 170V ignition voltage, for glow lamps with 90V ignition voltage approx. 1/2 glow lamp current. <sup>2)</sup> Glow lamp current independent from the ignition voltage. <sup>3)</sup> Depends on the set function. <sup>4)</sup> Will automatically be switched on starting at 110V control voltage. <sup>5)</sup> Control with 230V or low-voltage possible. <sup>6)</sup> If the control voltage is 230V, but the phase conductor is different than the 230V supply voltage, the universal voltage control input must be used due to the potential disconnection. <sup>7)</sup> At the control input . <sup>8)</sup> The relay contact can be open or closed when putting into operation. It will be synchronised at first operation. <sup>9)</sup> The switched consumer may not be connected to the mains before the short automatic synchronisation after installation has terminated. <sup>10)</sup> Patented Duplex technology: When switched with 230V/50Hz zero passage switching is activated if L is connected to (L) and N to (N). Then additional standby loss of only 0.1 Watt.

## ES12DX-UC

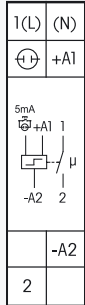

**1 NO contact potential free 16A/250V AC.  
Incandescent lamp load up to 2000W.  
No standby loss.**

Modular device for DIN-EN 60715 TH35 rail mounting.  
1 module = 18 mm wide, 58 mm deep.

**With the patented Eltako Duplex technology (DX) the normally potential-free contacts can still switch in zero passage when switching 230V AC 50Hz and therefore drastically reduce wear. Simply connect the neutral conductor to the terminal (N) and L to 1(L) for this. This results in a standby consumption of only 0.1 Watt.**

If the contact is used for controlling switching devices which do not perform zero passage switching themselves, (N) should not be connected because the additional closing delay otherwise causes the opposite effect.

**Either** universal control voltage 8 to 230V UC at the control input +A1/A2  
**or** 230V with glow lamp current up to 5 mA at the control input ⊕ (L)/-A2(N).

The simultaneous use of two potentials at the control inputs is not permitted.

Very low switching noise.

**No permanent power supply necessary, therefore no standby loss.**

State-of-the-art hybrid technology combines advantages of nonwearing electronic control with high capacity of special relays.

**By using a bistable relay coil power loss and heating is avoided even in the on mode.**

The relay contact can be open or closed when putting into operation. It will be synchronised at first operation.

Same terminal connection as the electromechanical impulse switch S12-100-.

**If this impulse switch is in a circuit, which is monitored by a FR12-230V mains disconnection relay, no additional base load is required. However, the monitoring voltage of the FR12-230V must be set to 'max'. Control only through A1-A2.**

### Typical connection

**Either** Universal control voltage 8 to 230V UC

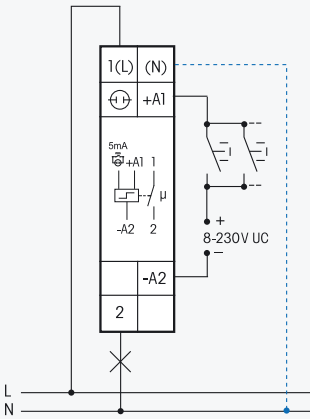

**or** control voltage 230V with glow lamp current up to 5 mA

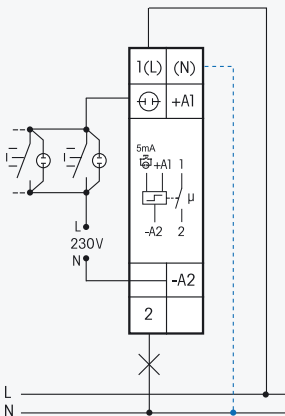

If N is connected, the zero passage switching is active.

This electronic switchgear represents the latest generation:

The electronics does not have an internal power supply and therefore no power is consumed in any contact position. A control current flows only during a short control impulse of 0.2 seconds. This activates the microcontroller, reads the last switching state from the non-voltage memory, switches the bistable relay to its opposite state accordingly and rewrites the new switching state to memory.

Technical data page A12. Housing for operating instructions GBA12 page Z5.

<b>ES12DX-UC</b>	1 NO 16A	EAN 4010312107959	<b>35,40 €/pc.</b>
------------------	----------	-------------------	--------------------

Recommended retail prices excluding VAT.

# Impulse Switch ES12-200

A2

**ES12-200-8..230V UC**

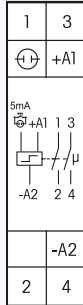

**2 NO contacts potential free 16A/250V AC.  
Incandescent lamp load up to 2000W.  
No standby loss.**

Modular device for DIN-EN 60715 TH35 rail mounting.  
1 module = 18 mm wide, 58 mm deep.

**Either** universal control voltage 8 to 230V UC at the control input +A1/A2  
**or** 230V with glow lamp current up to 5 mA at the control input  $\oplus$  (L)/-A2(N).

The simultaneous use of two potentials at the control inputs is not permitted.

Very low switching noise.

**No permanent power supply necessary, therefore no standby loss.**

State-of-the-art hybrid technology combines advantages of nonwearing electronic control with high capacity of special relays.

**By using a bistable relay coil power loss and heating is avoided even in the on mode.**

The relay contact can be open or closed when putting into operation. It will be synchronised at first operation.

Same terminal connection as the electromechanical impulse switch S12-200-.

Maximum current across both contacts 20A for 230V.

**If this impulse switch is in a circuit, which is monitored by a FR12-230V mains disconnection relay, no additional base load is required. However, the monitoring voltage of the FR12-230V must be set to 'max'.**

*This electronic switchgear represents the latest generation:*

*The electronics does not have an internal power supply and therefore no power is consumed in any contact position. A control current flows only during a short control impulse of 0.2 seconds. This activates the microcontroller, reads the last switching state from the non-voltage memory, switches the bistable relay to its opposite state accordingly and rewrites the new switching state to memory.*

### Typical connection

**Either** universal control voltage 8 to 230V UC

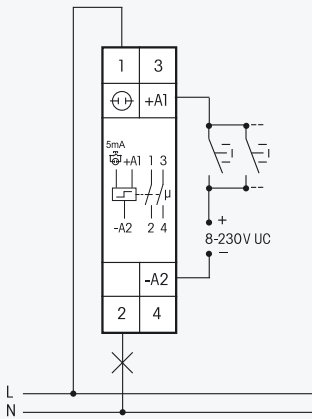

**or** control voltage 230V with glow lamp current up to 5 mA

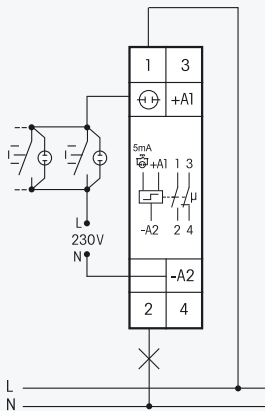

Technical data page A12. Housing for operating instructions GBA12 page Z5.

**ES12-200-8..230V UC**

2 NO 16A

EAN 4010312108048

**41,20 €/pc.**

Recommended retail prices excluding VAT.

## ES12-110-8..230V UC

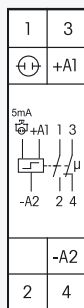

**1 NO contact + 1 NC contact potential free 16 A/250V AC.  
Incandescent lamp load up to 2000W.  
No standby loss.**

Modular device for DIN-EN 60715 TH35 rail mounting.  
1 module = 18 mm wide, 58 mm deep.

**Either** universal control voltage 8 to 230V UC at the control input +A1/A2  
**or** 230V with glow lamp current up to 5 mA at the control input ⊕ (L)/-A2 (N).

The simultaneous use of two potentials at the control inputs is not permitted.

Very low switching noise.

**No permanent power supply necessary, therefore no standby loss.**

State-of-the-art hybrid technology combines advantages of nonwearing electronic control with high capacity of special relays.

**By using a bistable relay coil power loss and heating is avoided even in the on mode.**

The relay contact can be open or closed when putting into operation. It will be synchronised at first operation.

Same terminal connection as the electromechanical impulse switch S12-110-.

**If this impulse switch is in a circuit, which is monitored by a FR12-230V mains disconnection relay, no additional base load is required. However, the monitoring voltage of the FR12-230V must be set to 'max'.**

*This electronic switchgear represents the latest generation:*

*The electronics does not have an internal power supply and therefore no power is consumed in any contact position. A control current flows only during a short control impulse of 0.2 seconds. This activates the microcontroller, reads the last switching state from the non-voltage memory, switches the bistable relay to its opposite state accordingly and rewrites the new switching state to memory.*

### Typical connection

**Either** universal control voltage 8 to 230V UC

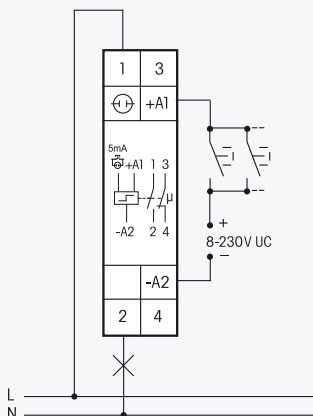

**or** control voltage 230V with glow lamp current up to 5 mA

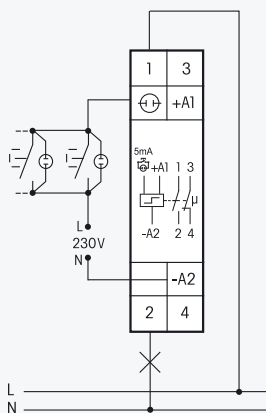

Technical data page A12. Housing for operating instructions GBA12 page Z5.

**ES12-110-8..230V UC**

1 NO+1 NC 16 A

EAN 4010312108055

**41,20 €/pc.**

Recommended retail prices excluding VAT.

# Impulse Switch with integrated relay function ESR12NP

A4

**ESR12NP-230V+UC**

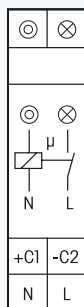

**1 NO contact not potential free 16A/250V AC. Incandescent lamp load up to 2300W. Off delay impulse switch with switch-off early warning and push-button permanent light switchable. Standby loss 0.5 watt only.**

Modular device for DIN-EN 60715 TH35 rail mounting.  
1 module = 18 mm wide, 58 mm deep.

**Zero passage switching** to protect contacts and lamps. This prolongs in particular the lifetime of energy saving lamps.

State-of-the-art hybrid technology combines advantages of nonwearing electronic control with high capacity of special relays.

Control voltage 230V. In addition electrically isolated universal voltage from 8 to 230V UC. Supply voltage and switching voltage 230V.

Very low switching noise. If the function ESV is set, definitely variable off-delay time RV from 2 to 120 minutes, settable by minute scale.

Contact position indication with two LEDs. This starts blinking in case of a blocked push-button (not if the function ER is set).

Glow lamp current up to 150 mA only at the control input 230V independent from ignition voltage (not if the function ER is set).

**Relays with suitable functions to feed back the switching voltage signal of a dimmer switch.**

In case of a power failure the system is disconnected in a preset sequence.

The functions ES, ESV or ER are selectable **by means of a rotary switch**.

**ES** = Impulse switch

**ER** = Switching relay

**ESV** = Impulse switch with off delay. The impulse switch automatically disconnects after the set delay is timed out if a manual OFF command has not been given. Infinitely variable time range up to 120 minutes.

**ESV** = If switch-off early warning  $\sqcup$  is set the stairwell lighting starts flickering approximately +  $\sqcup$  30 seconds before timeout at repeated shorter time intervals. During this process reset is possible.

**ESV** = If push-button permanent light  $\odot$  is set permanent light can be switched on by pressing longer than 1 sec. This switches off automatically after 2 hours or by an operation longer than 2 seconds.

**ESV** If both switch-off early warning function and permanent light by push-button  $\sqcup\odot$  are +  $\sqcup\odot$  set, the switch-off early warning function is activated before switching off the permanent light.

## Function rotary switches

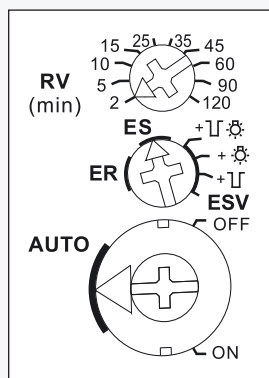

Standard setting ex factory.

$\sqcup$  = switch-off early warning

$\odot$  = push-button permanent light

$\sqcup\odot$  = switch-off early warning and push-button permanent light

## Typical connection

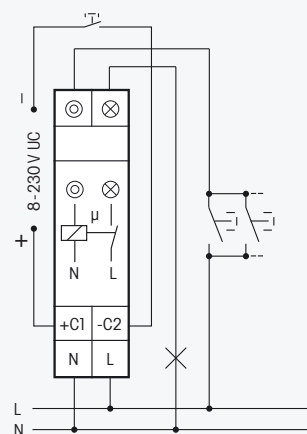

**If this impulse switch with integrated relay function is in a circuit, which is monitored by a FR12-230V mains disconnection relay, no additional base load is required. However, the monitoring voltage of the FR12-230V must be set to 'max'.**

Technical data page A12. Housing for operating instructions GBA12 page Z5.

**ESR12NP-230V+UC**

1 NO 16A

EAN 4010312107928

**39,10 €/pc.**

Recommended retail prices excluding VAT.

## ESR12DDX-UC



### 1 + 1 NO contacts potential free 16A/250V AC.

**Incandescent lamp load up to 2000W. Standby loss 0.03–0.4 watt only.**

Modular device for DIN-EN 60715 TH35 rail mounting.

1 module = 18 mm wide, 58 mm deep.

**With the patented Eltako Duplex technology (DX) the normally potential-free contacts can still switch in zero passage when switching 230V AC 50Hz and therefore drastically reduce wear. Simply connect the neutral conductor to the terminal (N) and L to 1(L) and/or 3(L) for this. This results in an additional standby consumption of only 0.1 Watt.**

**Universal control voltage 8 to 230V UC.** Supply voltage is same as the control voltage.

The functions are set with the keys MODE and SET as described in the operating instructions. They are indicated on the display and can be blocked if required.

**The accrued switch-on time** is continuously displayed. First in hours (h), then in months (m) with 1 digit after the decimal point.

**By using bistable relays coil power loss and heating is avoided even in the on mode.**

The switched consumer may not be connected to the mains before the short automatic synchronisation after installation has terminated.

Only impulse switch functions: After a power failure the system is disconnected in a definite sequence or the switch position is kept depending on the setting (then + on the display next to function abbreviations). Settings under RSM in the menu guidance. Furthermore, when using these functions, with the keys MODE and SET, the control inputs A1 and A3 can be defined as central control inputs.

**ZA1** = 'central off' with A1, local with A3; **ZE1** = 'central on' with A1, local with A3;

**Z00** = no central control. 'Central on' with A1, 'central off' with A3. No local control refer to function RS.

**Relays with suitable functions to feed back the switching voltage signal of a dimmer switch.**

From 110V control voltage and in the settings 2S, WS, SS and GS glow lamp current up to 5mA, dependent on the ignition voltage.

**With the keys MODE and SET you can select amongst 18 functions:**

**OFF** = Permanent OFF

**2xS** = 2-fold impulse switch with 1 NO contact each, control inputs A1 and A3

**2S** = Impulse switch with 2 NO contacts

**WS** = Impulse switch with 1 NO contact and 1 NC contact

**SS1** = Impulse multi circuit switch 1 + 1 NO contacts for switching sequence  
0 - contact 1 (1-2) - contact 2 (3-4) - contacts 1 + 2

**SS2** = Impulse multi circuit switch 1 + 1 NO contacts for switching sequence  
0 - contact 1 - contacts 1 + 2 - contact 2

**SS3** = Impulse multi circuit switch 1 + 1 NO contacts for switching sequence  
0 - contact 1 - contacts 1 + 2

**GS** = Impulse group switch 1 + 1 NO contacts for switching sequence  
0 - contact 1 - 0 - contact 2

**RS** = Switch with 2 NO contacts, with A1 = set control input and A3 = reset control input

**2xR** = 2-fold switching relay with 1 NO contact each, control inputs A1 and A3

**2R** = Switching relay with 2 NO contacts

**WR** = Switching relay with 1 NO contact and 1 NC contact

**RR** = Switching relay (closed-circuit current relay) with 2 NC contacts

**EAW** = Impulse relay for fleeting NO contact and fleeting NC contact with 1 + 1 NO contacts, wiping time 1 sec each

**EW** = Impulse relay for fleeting NO contact with 1 NO contact and 1 NC contact, wiping time 1 sec

**AW** = Impulse relay fleeting NC contact with 1 NO contact and 1 NC contact, wiping time 1 sec

**GR** = Group relay 1 + 1 NO contacts (relay with alternating closing contacts)

**ON** = Permanent ON

The control inputs A1 and A3 have the same functions except for 2xS, 2xR and RS, if not used as central control inputs.

After setting the required function, the function can be blocked.

An arrow on the right of the abbreviation indicates the blocking status.

### Typical connection

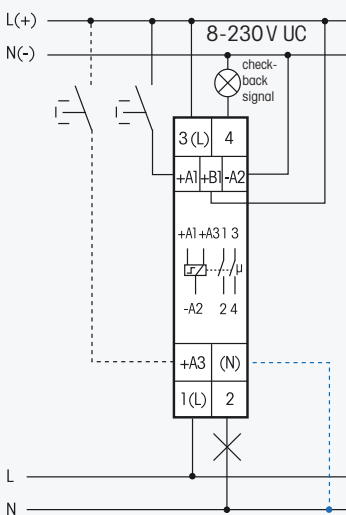

If N is connected, the zero passage switching is active.

Technical data page A12. Housing for operating instructions GBA12 page Z5.

**ESR12DDX-UC**

1+1 NO 16A

EAN 4010312108093

**53,50 €/pc.**

Recommended retail prices excluding VAT.

# Impulse Switch with potential free contacts ES12Z, also for central control

A6

## ES12Z-200-UC



**2 NO contacts potential free 16A/250V AC.**

**Incandescent lamp load up to 2000W. Standby loss 0.03–0.4 watt only.**

**Central control priorities selectable.**

Modular device for DIN-EN 60715 TH35 rail mounting. 1 module = 18 mm wide, 58 mm deep. State-of-the-art hybrid technology combines advantages of nonwearing electronic control with high capacity of special relays.

Local universal control voltage 8 to 230 V UC.

In addition control inputs 8 to 230 V UC central ON and central OFF, electrically isolated from the local input. Supply voltage same as the local control voltage. Very low switching noise. Glow lamp current starting at 110 V control voltage up to 50 mA in positions 1 to 3 and 5 to 7 of the rotary switch.

**By using a bistable relay coil power loss and heating is avoided even in the on mode.**

The switched consumer may not be connected to the mains before the short automatic synchronisation after installation has terminated.

Maximum current across both contacts 20A for 230V. Contact position indication with LED. This starts blinking after 15 seconds in case of a inhibited push-button, not in position 4+8 of the rotary switch.

**With the upper rotary switch** this impulse switch can be partly or completely excluded from central control:

**ZE+ZA** = 'Central ON' and 'Central OFF' are active. You can select a response delay of 0, 1, 2 or 3 seconds for 'Central ON'. **ZE** = Only 'Central ON' is active. You can select a response delay of 0, 1, 2 or 3 seconds. **ZA** = Only 'Central OFF' is active. **ZE+ZA** = No central control is active.

**The lower rotary switch** sets several priorities. These determine which other control inputs are inhibited as long as another control input is excited permanently.

Furthermore, here it is decided if the switch position should be kept or not after a power failure: In positions 1 to 4 of the rotary switch the switch position remains unchanged, in positions 5 to 8 it is switched off. Incoming central commands are executed immediately after the power supply returns.

**OFF** = Permanent OFF, **ON** = Permanent ON

**1 and 5** = No priority. Also if central control inputs are excited permanently, it is possible to operate the device by pushing a local push-button. The last central command is executed. This is the setting ex factory.

**2 and 6** = Priority for central ON and OFF. Local push-buttons are temporarily inhibited. However, continuous excitation central OFF has priority over continuous excitation central ON.

**3 and 7** = Priority for central ON and OFF. Local push-buttons are temporarily inhibited. However, continuous excitation central ON has priority over continuous excitation central OFF.

**4 and 8** = Priority for permanently excited local push-button. In the meantime central commands are not executed. In these positions a glow lamp current is not permitted.

### Function rotary switches

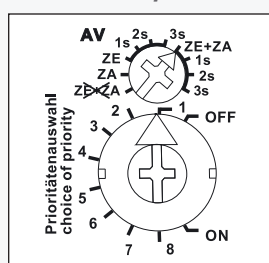

Standard setting ex factory.

### Typical connection

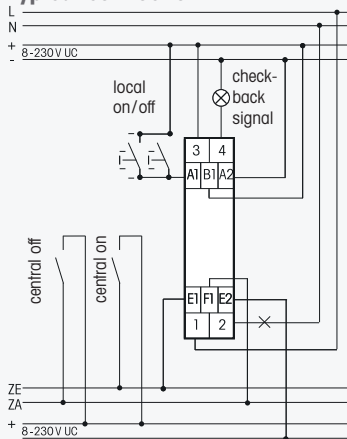

Technical data page A12.

**ES12Z-200-UC**

2 NO 16A

EAN 4010312107690

**50,80 €/pc.**

## ES12Z-110-UC

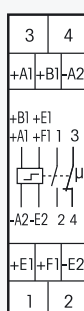

**1 NO contact + 1 NC contact potential free 16A/250 V AC.**

**Incandescent lamp load up to 2000W.**

**Standby loss 0.03–0.4 watt only. Central control priorities selectable.**

All functions same as ES12Z-200, but with 1 NO contact and 1 NC contact.

Technical data page A12. Housing for operating instructions GBA12 page Z5.

**ES12Z-110-UC**

1 NO + 1 NC 16 A

EAN 4010312107683

**50,80 €/pc.**

Recommended retail prices excluding VAT.

## ESR12Z-4DX-UC

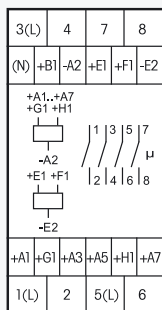
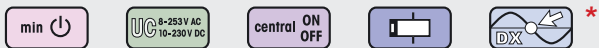

**Also for central control and group control. With 4 independent contacts, 1 NO contact each potential free 16A/250V AC, incandescent lamp load up to 2000W. Standby loss 0.03–0.4 watt only.**

Modular devices for DIN-EN 60715 TH35 rail mounting. 2 modules = 36mm wide, 58mm deep.

**\* Patented Eltako Duplex technology (DX) allows you to switch 3 of the 4 normally potential free contacts in zero passage switching when 230V A/C voltage 50Hz is switched. This drastically reduces wear. To achieve this, simply connect the N conductor to the terminal (N) and the phase conductors to 1(L), 3(L) or 5(L). This results in an additional standby consumption of only 0.1 watt.** If the channels are used to control switchgear that has no zero passage switching, (N) should not be connected, otherwise the additional off-delay would have the opposite effect.

Local universal control voltage 8 to 230V UC. In addition universal control inputs central ON and central OFF for 8 to 230V UC, electrically isolated from the local inputs.

**With additional group control inputs ON and OFF for 8..230V UC.** Same potential like the local control inputs. Groups of these impulse switches can be controlled separately using the group control inputs.

Supply voltage like the local control voltage.

**By using a bistable relay coil power loss and heating is avoided even in the on mode.**

The switched consumers may not be connected to the mains before the short automatic synchronisation after installation has terminated. Central commands always have priority, local control inputs are blocked as long as central commands are activated. In case of a power failure the system is disconnected in a defined mode.

**With the upper rotary switch** this impulse switch with integrated relay function can be partly or completely excluded from central control:

ZE+ZA = central ON and central OFF      ZE = central ON only  
ZA = central OFF only      ~~ZE+ZA~~ = no central control

**With the middle rotary switch ES/ER the functions of the lower rotary switch will be preselected. The setting ER selects the function in brackets. Not suitable to feed back the switching voltage signal of a dimmer switch. Use only relays ESR12DDX-UC, ESR12NP-230V+UC or ESR61NP-230V+UC for this purpose. With the lower rotary switch 18 different functions may be selected:**

**ON** = Permanent ON

**4xS** = 4-fold impulse switch with 1 NO contact each, control inputs A1, A3, A5 and A7

**(4xR)** = 4-fold switching relay with 1 NO contact each, control inputs A1, A3, A5 and A7

**4S** = Impulse switch with 4 NO contacts

**(4R)** = Switching relay with 4 NO contacts

**2S/WS** = Impulse switch with 3 NO contacts and 1 NC contact

**(2R/WR)** = Switching relay with 3 NO contacts and 1 NC contact

**2WS** = Impulse switch with 2 NO contacts and 2 NC contacts

**(2WR)** = Switching relay with 2 NO contacts and 2 NC contacts

**SSa** = Impulse multi circuit switch 2+2 NO contacts for switching sequence 0-2-2+4-2+4+6; check back signal 8

**(4RR)** = closed-circuit current relay with 4 NC contacts

**SSb** = Impulse multi circuit switch 2+2 NO contacts for switching sequence 0-2-2+4-2+4+6-2+4+6+8

**(EW)** = Impulse relay for fleeting NO contact with 3 NO contacts and 1 NC contact, wiping time 1 sec

**GS** = Impulse group switch. Switching sequence 0-2-0-4-0-6-0; check back signal 8

**(AW)** = Impulse relay fleeting NC contact with 3 NO contacts and 1 NC contact, wiping time 1 sec

**RS** = Switch with 4 NO contacts, A1= set control input and A3 = reset control input

**(GR)** = Group relay 1+1+1+1 NO contacts

**3xS+** = 3-fold impulse switch with 1 NO contact each + check back signal 8, control inputs A1, A3 and A5

**(3xR+)** = 3-fold switching relay with 1 NO contact each + check back signal 8, control inputs A1, A3 and A5

### Function rotary switches

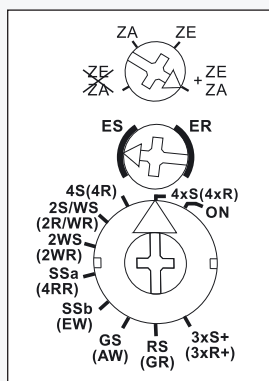

Standard setting ex factory.

### Typical circuit with central control and group control

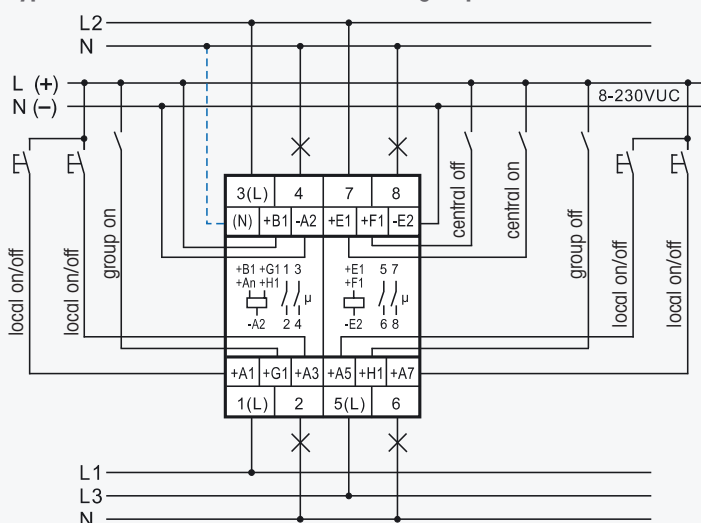

If N is connected, the zero passage switching is active at the contacts 1-2, 3-4 and 5-6.

Technical data page A12. Housing for operating instructions GBA12 page Z5.

<b>ESR12Z-4DX-UC</b>	4 x 1 NO 16 A	EAN 4010312108130	<b>87,80 €/pc.</b>
----------------------	---------------	-------------------	--------------------

## ES61-8..230 V UC

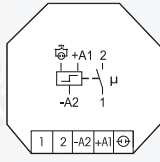

**1 NO contact potential free 10 A/250 V AC. Incandescent lamp load up to 2000 W. No standby loss.**

For installation. 45 mm long, 55 mm wide, 18 mm deep.

State-of-the-art hybrid technology combines advantages of nonwearing electronic control with high capacity of special relays.

**Either** universal control voltage 8 to 230 V UC at the control input +A1/-A2

**or** 230 V with a glow lamp current up to 5 mA at the control input  $\ominus$  (L)/-A2 (N).

Using two potentials simultaneously at the control inputs is not permitted.

Very low switching noise.

**No permanent power supply necessary, therefore no standby loss.**

**By using a bistable relay coil power loss and heating is avoided even in the on mode.**

The relay contact can be open or closed when putting into operation. It will be synchronised at first operation.

**If this impulse switch is in a circuit, which is monitored by a FR12-230 V mains disconnection relay, no additional base load is required. However, the monitoring voltage of the FR12-230 V must be set to 'max'.**

### Typical connection

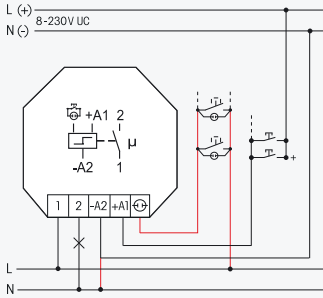

This electronic switchgear represents the latest generation:

The electronics does not have an internal power supply and therefore no power is consumed in any contact position. A control current flows only during a short control impulse of 0.2 seconds. This activates the microcontroller, reads the last switching state from the non-voltage memory, switches the bistable relay to its opposite state accordingly and rewrites the new switching state to memory.

Technical data page A12. Short-stroke pushbuttons page Z1-Z3.

**ES61-8..230V UC**

1 NO 10A

EAN 4010312107966

**38,80 €/pc.**

Recommended retail prices excluding VAT.

## ESR61NP-230V+UC

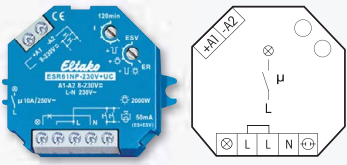

**1 NO contact not potential free 10 A/250 V AC, incandescent lamp load up to 2000W. Off delay impulse switch with switch-off early warning and push-button permanent light switchable. Standby loss 0.7 watt only.**

For installation. 45mm long, 55mm wide, 18mm deep.

**Zero passage switching** to protect contacts and lamps. This prolongs in particular the lifetime of energy saving lamps.

State-of-the-art hybrid technology combines advantages of nonwearing electronic control with high capacity of special relays.

**By using a bistable relay coil power loss and heating is avoided even in the on mode.**

The switched consumer may not be connected to the mains before the short automatic synchronisation after installation has terminated.

Control voltage 230V. In addition electrically isolated universal control voltage from 8 to 230V UC. Supply voltage and switching voltage 230V. Very low switching noise. Variable time range up to 120 minutes in the function **ESV**. At the control input push-buttons with a glow lamp current up to 50mA can be connected. In case of a power failure the system is disconnected in a preset sequence.

If the timing period is set to minimum in the function **ESV**, the release delay is switched off. The standard impulse switch function **ES** is then set. The function **ER** is selectable. If the function **ER** is selected a glow lamp current is not permitted. Only the control input A1- A2 should be used.

**When set to the function ER this device is suitable to feed back the switching voltage signal of a dimmer switch.**

**If switch-off early warning function is switched on, the light starts flickering approx. 30 seconds before time-out. This is repeated three times at decreasing time intervals.**

**If the permanent light function is switched on, the function can be activated by pressing the push-button for longer than 1 second. This function switches off automatically after 2 hours or by pressing the push-button for longer than 2 seconds.**

If both switch-off early warning function and permanent light by push-button are set, the switch-off early warning function is activated before switching off the permanent light.

### Function rotary switches

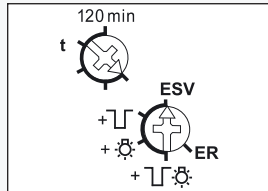

Standard setting ex factory.

### Typical connection

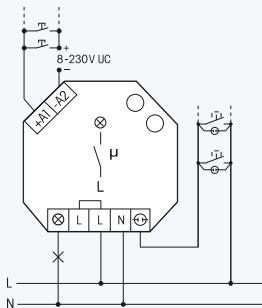

### Side view

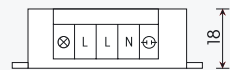

Technical data page A12. Short-stroke pushbuttons page Z1-Z3.

**ESR61NP-230V+UC**

1 NO 10A

EAN 4010312107911

**39,20 €/pc.**

Recommended retail prices excluding VAT.

# Multifunction Impulse Switch with integrated relay function ESR61M

A10

## ESR61M-UC

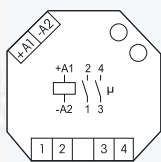

**1+1 NO contacts potential free 10A/250V AC.  
Incandescent lamp load up to 2000W. No standby loss.**

For installation. 45 mm long, 55 mm wide, **32 mm deep.**

State-of-the-art hybrid technology combines advantages of nonwearing electronic control with high capacity of special relays.

Universal control voltage 8 to 230V UC.

**No permanent power supply necessary, therefore no standby loss.**

**By using bistable relays coil power loss and heating is avoided even in the on mode.**

The switched consumer may not be connected to the mains before the short automatic synchronisation after installation has terminated.

The functions of the second rotary switch are preselected using the rotary switch ES/ER. The setting ER selects the function in brackets. 10 different functions are selectable.

**2S** = Impulse switch with 2 NO contacts

**(2R)** = Switching relay with 2 NO contacts

**WS** = Impulse switch with 1 NO contact and 1 NC contact

**(WR)** = Switching relay with 1 NO contact and 1 NC contact

**SS1** = Impulse multi circuit switch 1+1 NO contacts for switching sequence  
0 - contact 1 (1-2) - contact 2 (3-4) - contacts 1 + 2

**(RR)** = Switching relay (closed-circuit current relay) with 2 NC contacts

**SS2** = Impulse multi circuit switch 1+1 NO contacts for switching sequence  
0 - contact 1 - contacts 1 + 2 - contact 2

**(EW)** = Impulse relay for fleeting NO contact with 1 NO contact and 1 NC contact,  
wiping time 1 sec

**GS** = Impulse group switch 1+1 NO contacts for switching sequence  
0 - contact 1 - 0 - contact 2

**(GR)** = Group relay 1+1 NO contacts (relay with alternating closing contacts)

**This relay is not suitable to feed back the switching voltage signal of a dimmer switch. Use only relays ESR12DDX-UC, ESR12NP-230V+UC or ESR61NP-230V+UC for this purpose.**

### Function rotary switches

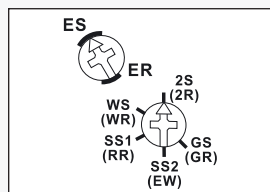

Standard setting ex factory.

### Typical connection

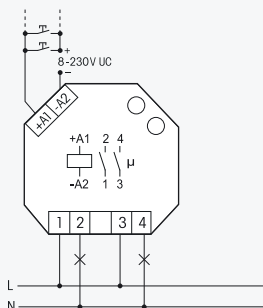

### Side view

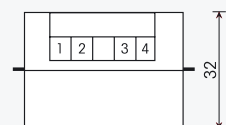

This electronic switchgear represents the latest generation:

The electronics does not have an internal power supply and therefore no power is consumed in any contact position. A control current flows only during a short control impulse of 0.2 seconds. This activates the microcontroller, reads the last switching state from the non-voltage memory, switches the bistable relay to its opposite state accordingly and rewrites the new switching state to memory.

Technical data page A13. Short-stroke pushbuttons page Z1-Z3.

**ESR61M-UC**

1 + 1 NO 10A

EAN 4010312108079

**50,80 €/pc.**

Recommended retail prices excluding VAT.

## ES75-12..24 V UC

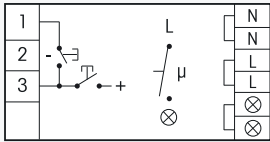
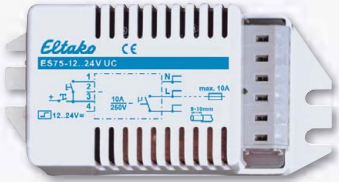

<sup>1)</sup> For lamps with 150W max.

### For installation in lighting fittings.

**1 NO contact not potential free 10A/250V AC. Standby loss 0.1 watt only.**

Built-in device for installation. 85 mm long, 40 mm wide, 28 mm deep.

With integrated transformer for electrical isolation between control circuit and switching circuit to comply with the requirements for safety extra-low voltage.

Control voltage 12 to 24 V UC, control current 10 mA at 24 V. Continuous power supply 230 V.

Incandescent lamps and halogen lamps load up to 500 W<sup>1)</sup> and fluorescent lamps with conventional ballast units in lead-lag circuit up to 1000 VA.

Fluorescent lamps with conventional ballast units parallel compensated 300 VA.

Temperatures at the mounting location between -20°C and +50°C.

Min. command pulse duration/command pause 20/300 ms.

Connections on the low voltage side: 4-pole pin receptacle for STOCKO MKF 13264-6-0-404 plug, 230 V connections: 6-pole terminal strip with plug-in terminals. max. conductor cross section 2.5 mm<sup>2</sup>.

One STOCKO plug comes with each device.

# Technical Data Electronic Impulse Switches, also for central control

A12

Contacts	ES12DX <sup>a)</sup> ES12-200 <sup>a)</sup> ES12-110 <sup>a)</sup>	ESR12NP	ESR12DDX <sup>b)</sup>	ES12Z <sup>b)</sup> ESR12Z-4DX <sup>b)</sup>	ES61 <sup>a)</sup> ESR61M <sup>a)</sup>	ESR61NP <sup>b)</sup>
Contact material / contact gap	AgSnO <sub>2</sub> /0.5 mm	AgSnO <sub>2</sub> /0.5 mm	AgSnO <sub>2</sub> /0.5 mm	AgSnO <sub>2</sub> /0.5 mm	AgSnO <sub>2</sub> /0.5 mm	AgSnO <sub>2</sub> /0.5 mm
Spacing of control connections/contact control connections C1-C2 or A1-A2/contact	6 mm –	3 mm 6 mm	6 mm –	6 mm –	3 mm ESR61M: 6 mm	3 mm 6 mm
Test voltage contact/contact	ES12-200/110: 2000 V	–	4000 V	4000 V	ESR61M: 2000 V	–
Test voltage control connection/contact Test voltage C1-C2 or A1-A2/contact	4000 V –	2000 V 4000 V	4000 V –	4000 V –	2000 V 4000 V	2000 V 4000 V
Rated switching capacity	16A/250V AC	16A/250V AC	16A/250V AC	16A/250V AC	10A/250V AC	10A/250V AC
Incandescent lamp and halogen lamp load <sup>1)</sup> 230 V	2000 W	2000 W	2000 W	2000 W	2000 W	2000 W
Fluorescent lamp load with KVG* in lead-lag or non compensated	1000 VA	1000 VA	1000 VA	1000 VA	1000 VA	1000 VA
Fluorescent lamp load with KVG* shunt-compensated or with EVG*	500 VA	500 VA	500 VA	500 VA	500 VA	500 VA
Compact fluorescent lamps with EVG* and energy saving lamps ESL	I on ≤ 70 A/ 10 ms <sup>2) 3)</sup> ES12DX: 15x7 W 10x20 W <sup>3)</sup>	15x7 W 10x20 W	I on ≤ 70 A/ 10 ms <sup>2)</sup>	I on ≤ 70 A/ 10 ms <sup>2) 3)</sup> ESR12Z-4DX: 15x7 W 10x20 W <sup>3)</sup>	I on ≤ 70 A/ 10 ms <sup>2)</sup>	15 x 7 W 10 x 20 W
Max. switching current DC1: 12 V/24 V DC	8 A	–	8 A	8 A	8 A	–
Life at rated load, cos φ = 1 resp. for incandescent lamps 1000 W at 100/h	> 10 <sup>5</sup>	> 10 <sup>5</sup>	> 10 <sup>5</sup>	> 10 <sup>5</sup>	> 10 <sup>5</sup>	> 10 <sup>5</sup>
Life at rated load, cos φ = 0.6 at 100/h	> 4 x 10 <sup>4</sup>	> 4 x 10 <sup>4</sup>	> 4 x 10 <sup>4</sup>	> 4 x 10 <sup>4</sup>	> 4 x 10 <sup>4</sup>	> 4 x 10 <sup>4</sup>
Max. operating cycles	10 <sup>3</sup> /h	10 <sup>3</sup> /h	10 <sup>3</sup> /h	10 <sup>3</sup> /h	10 <sup>3</sup> /h	10 <sup>3</sup> /h
Maximum conductor cross-section (3-fold terminal)	6 mm <sup>2</sup> (4 mm <sup>2</sup> )	6 mm <sup>2</sup> (4 mm <sup>2</sup> )	6 mm <sup>2</sup> (4 mm <sup>2</sup> )	6 mm <sup>2</sup> (4 mm <sup>2</sup> )	4 mm <sup>2</sup>	4 mm <sup>2</sup>
Two conductors of same cross-section (3-fold terminal)	2.5 mm <sup>2</sup> (1.5 mm <sup>2</sup> )	2.5 mm <sup>2</sup> (1.5 mm <sup>2</sup> )	2.5 mm <sup>2</sup> (1.5 mm <sup>2</sup> )	2.5 mm <sup>2</sup> (1.5 mm <sup>2</sup> )	1.5 mm <sup>2</sup>	1.5 mm <sup>2</sup>
Screw head	slotted/crosshead, pozidriv			slotted/crosshead		
Type of enclosure/terminals	IP50/IP20			IP30/IP20		
<b>Electronics</b>						
Time on (also for central on/off)	100 %	100 %	100 %	100 %	100 %	100 %
Max./min. temperature at mounting location	+50°C/-20°C	+50°C/-20°C	+50°C/-20°C	+50°C/-20°C	+50°C/-20°C	+50°C/-20°C
Standby loss (active power) 230V	–	0.5 W	0.4 W	0.4 W	–	0.7 W
Standby loss (active power) 12V <sup>4)</sup>	–	–	0.03 W	0.03 W	–	–
Control current 230V-control input local (<10 s)	25 mA	10 mA	–	–	25 mA ESR61M: –	10 mA
Control current universal control voltage all control voltages (< 5 s) ± 20 % 8/12/24/230V (<10 s) ± 20 %	1.5 mA (15 mA) ⊕ 30(23) mA	– 2/4/9/5 (100) mA	– 2/3/7/3 (50) mA	– 0.1/0.1/0.2/1 (30) mA	1.5 mA (15 mA) ESR61M: 4 mA	– 2/4/9/5 (100) mA
Control current central 8/12/24/230V (<10 s) ± 20 %	–	–	–	2/4/9/5 (100) mA	–	–
Max. parallel capacitance (approx. length) of single control lead at 230 V AC	⊕ 0.3 μF (1000 m) A1-A2: 0.06 μF (200 m)	ES: 0.3 μF (1000 m) ER: 3 nF (10 m) C1-C2: 15 nF (50 m)	0.3 μF (1000 m)	0.3 μF (1000 m)	⊕ : 0.3 μF (1000 m) A1-A2: 0.06 μF (200 m) ESR61M: 0.5 nF (2 m)	⊕ 0.06 μF (200 m) A1-A2: 0.3 μF (1000 m)
Max. parallel capacitance (approx. length) of central control lead at 230 V AC	–	–	–	0.9 μF (3000 m)	–	–

\* EVG = electronic ballast units; KVG = conventional ballast units <sup>a)</sup> Bistable relay as relay contact. The relay contact can be open or closed when putting into operation. It will be synchronised at first operation. <sup>b)</sup> Bistable relay as relay contact. The switched consumer may not be connected to the mains before the short automatic synchronisation after installation has terminated. <sup>1)</sup> For lamps with 150 W max. <sup>2)</sup> A 40-fold inrush current must be expected for electronic ballast devices. For steady loads of 1200W or 600W use the current-limiting relay SBR12 or SBR61. Product group G, page G4. <sup>3)</sup> When using DX types close attention must be paid that zero passage switching is activated! <sup>4)</sup> Standby loss at 24 V approx. two times greater than at 12V.