

## Constant light controller FKR12



The automatic energy savers

### 1-10V constant light controller FKR12/1-10V

for 1-10V-electronic ballasts



Page 3

### Constant light controller FKR12UD-12V DC

for dimmable energy saving lamps (ESL)  
and 230V LED lamps, halogen lamps  
and glow lamps



Page 4

**Optimum convenience and maximum energy savings at the same time.**

Unbelievable but true – with our new automatic constant light controllers FKR12.

- FKR12/1-10V and FKR12UD provide fully automatic artificial light control depending on daylight intensity.
- FKR12/1-10V controls 1-10V electronic ballasts for fluorescent lamps.
- FKR12UD controls dimmable energy saving lamps (ESL), 230V LED lamps, halogen lamps and glow lamps.
- The wireless motion and brightness sensor FBH63 switches off the lights provided it detects no movement in the room or it automatically switches on when someone enters the room.
- Individual setting options meet all your requirements. It is possible to adapt to all room conditions. From a kitchen at home to an open office. Or adjust the brightness for example for a beamer presentation and for emergency lighting.

## This is how the constant light control FKR works

A wireless motion and brightness sensor FBH63AP attached without cables or wires to the ceiling or a wireless outdoor brightness sensor FAH60 and FABH63 mounted outside transmits its data to one or several FKR12/1-10V and/or FKR12UD mounted in the distributor and this dims the lamps in the room by wire. The universal dimmers FKR12UD perform this directly; the FKR12/1-10Vs switch fluorescent lamps and dim their 1-10V electronic ballasts.

**The minimum configuration** consists of a wireless sensor FBH63AP and/or FAH60, a 1 module wide wireless antenna module FAM12, a 1 module wide FKR12/1-10V or FKR12UD and a 12V power supply, e.g. the 1 module wide switch mode power supply unit FSNT12-12V/12W. The space requirement in the distributor is therefore only 3 modules for a switching capacity of 500W and 600VA. With only one additional module the switching capacity can be increased to include further lamps by 500 watts (FKR12UD) and 600VA (FKR12/1-10V). There are practically no limits here since up to 128 FKR12s can then be connected to a FAM12. Additional FBH63APs can be fitted in large rooms for motion detection without having to expand using additional hardware.

The installation is completed with one or several wireless switches FT4 and a double rocker. The left hand rocker switches the light on and off manually in operating modes "Semiautomatic" and "Brightness-controlled switch-off". In addition the automatic control can be oversteered to obtain more or less artificial light.

The right hand rocker, for example, can be programmed to control the roller shutters or blinds in conjunction with the adjustable beamer brightness and a further light source or a universal switch for the wireless switch actuator FSB12.

Wireless hand-held transmitters FHS, mini hand-held transmitters FMH and/or universal remote controls UFB-Harmony One+E with wireless infrared converter FIW55 or FIW-USB can be taught-in as an additional measure or instead of wireless switch FT4 to control additional shading elements with direction switches. They must then be switched with 1 module wide switching actuators each with 2 motors for shading elements/roller shutters FSB12. Other additional hardware is not required to do this since the wireless antenna module FAM12 and the power supply are already installed.

## Typical connection for wireless antenna module with wireless switching actuators connected in series

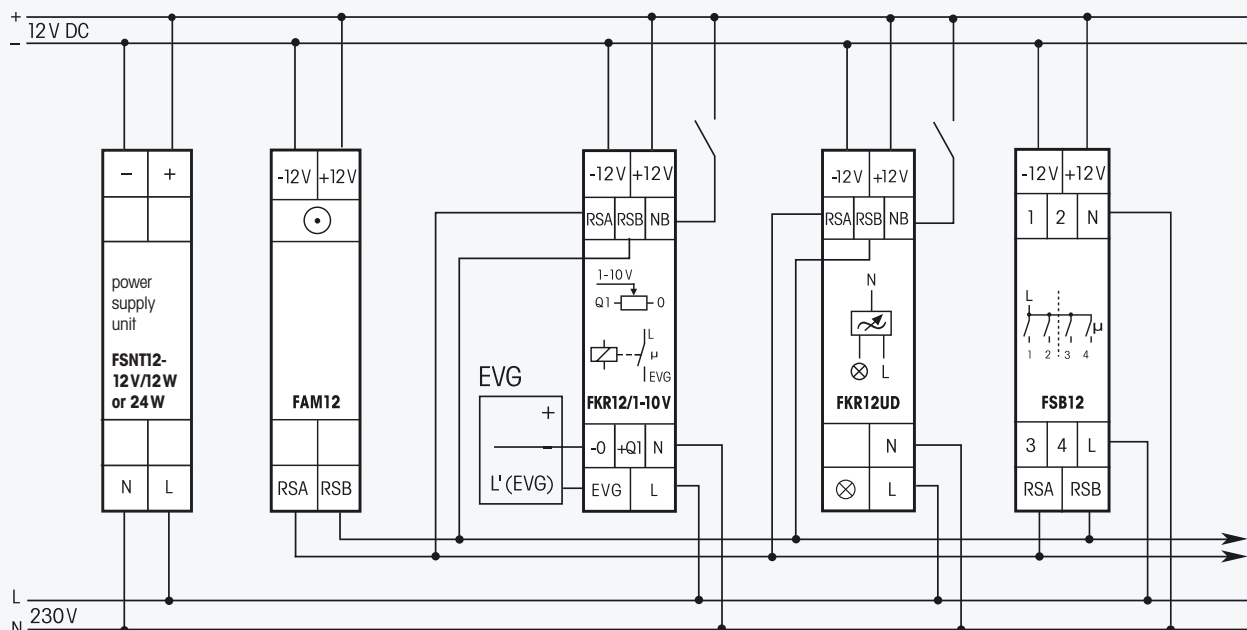

**FKR12/1-10V**

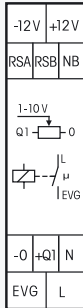

**Dimming actuator 1 channel, 1 NO contact not potential free 600 VA and 1-10V control output 40 mA. Only 0.9 watt standby loss. Motion-dependent and brightness-dependent light control with the wireless motion/brightness sensor FBH.**

Modular device for DIN-EN 60715 TH35 rail mounting. 1 module = 18mm wide, 58mm deep. State-of-the-art hybrid technology combines advantages of nonwearing electronic control with high capacity of special relays.

**Zero passage switching to protect contacts.**

The 12V DC supply voltage of the complete RS485 bus is mainly powered at 12 W or 24 W by a switch mode power supply unit FSNT12-12V that is only 1 or 2 pitch units wide. The power consumption of the 12 V DC power supply is only 0.05 W.

The brightness level is stored on switch-off (memory).

In case of a power failure the switch position and the brightness stage are stored and may be switched on when the power supply is restored.

**Connection to the Eltako RS485 bus, terminals RSA and RSB.**

**Up to a total of 128 actuators can be added in this way.**

**By using a bistable relay coil power loss and heating is avoided even in the on mode.**

After installation, wait for short automatic synchronisation before the switched consumer is connected to the mains.

**Function of FKR12**

The wireless constant light controller FKR12 receives its signals from one or several wireless sensors FBH via a wireless antenna module FAM12-12V DC and then controls the 1-10V output or switches the light on or off.

3 operation modes **BA** can be selected: **1 = fully automatic** (switch-on and switch-off is brightness and motion controlled), **2 = semi-automatic** (only switch-off is brightness and motion controlled) and **3 = switch-off is brightness controlled** (motion sensor is not active).

**With one wireless pushbutton or wireless hand-held transmitter the automatic system can be overloaded to a preset value in order to dim the light for a beamer presentation, for example.**

Several FBH can be taught-in in a FKR12. As long as one of the motion detection sensors FBH detects activity, the necessary lighting remains on and only after all FBHs report no activity for 1 minute does the adjustable time delay RV commence.

Only 1 FBH (Master) is used for the constant light control.

The FBHs can also be taught-in in several FKR12s. This not only allows an increase in the total switching capacity but also the set-up of zones with different brightness settings by setting different basic brightness values GH. Several independent FKR12 systems can be installed simultaneously.

**To teach-in wireless pushbuttons and wireless hand-held transmitters, one rocker is taught-in as direction switches.**

Tap the bottom part to switch the light off. Press the top or bottom to dim up or down. This shifts the control automatic towards brighter or darker. A double tap on the bottom part dims down to the taught-in value 'Beamer Presentation'. When the light is switched off and the top part is held down, the light is dimmed up from the lowest brightness level until the rocker is released. Resetting to automatic control is effected either by automatic light switch-off or by double-tapping the top direction switch.

The beamer value can additionally be taught-in in a further universal switch.

**In addition to the beamer value the minimum brightness and the brightness for emergency lighting can be set and stored.**

As long as the control input NB is connected to +12V DC, it is dimmed to the set brightness for emergency lighting. All wireless signals are ignored then.

**The upper rotary switch LRN** is required for teach-in and for setting the base brightness.

**The middle rotary switch RV** is set after teach-in to the required delay time from 0 to 10 minutes. There is also an additional 1 minute of FBH.

The base brightness **GH** dependent on use of the room is set **with the lower rotary switch plus the upper rotary switch** adding the adjusted values. The smallest settable value is 1 (0+1), the largest value is 40 (30+10). The normal setting is approx. at 21.

**The LED** below the upper function rotary switch performs during the teach-in process according to the operation manual. It shows control commands by short flickering during operation.

**Function rotary switches**

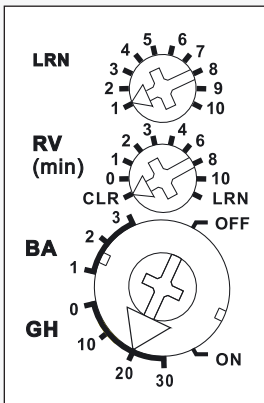

Standard setting ex works.

**Typical connection**

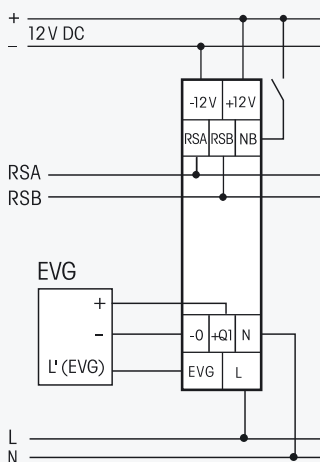

Connection example page 2, technical data page 12.

**Teach-in according to the operation manual. Also under [www.eltako.com](http://www.eltako.com).**

**FKR12/1-10V**

RS485 bus dimming actuator constant light controller

EAN 4010312300923

**53,80 €/pc.**

# RS485 Bus Dimming Actuator Constant Light Controller FKR12UD with Universal Dimmer Switch

**FKR12UD-12V DC**

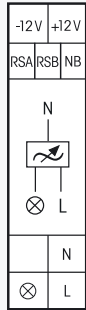

**Universal dimming actuator 1 channel, Power MOSFET up to 500W, ESL up to 100W and LED up to 100W. Only 0.3 watt standby loss. Motion-dependent and brightness-dependent light control of dimmable energy saving lamps ESL and 230V LED lamps, incandescent and halogen lamps with the wireless motion/brightness sensor FBH or wireless outdoor brightness sensor FAH.**

Modular device for DIN-EN 60715 TH35 rail mounting. 1 module = 18 mm wide, 58 mm deep. Universal dimmer switch for R, L and C loads up to 500 watts, depending on ventilation conditions. Automatic detection of load R+L or R+C. ESL and LED is manually settable. Dimmable energy saving lamps ESL up to 100 watts and dimmable 230V LED lamps up to 100 watts.

**Zero passage switching with soft ON and soft OFF to protect lamps.**

The 12V DC supply voltage of the complete RS485 bus is mainly powered at 12W or 24W by a switch mode power supply unit FSNT12-12V that is only 1 or 2 pitch units wide. The power consumption of the 12V DC power supply is only 0.05W.

The brightness level is stored on switch-off (memory). In case of a power failure the switch position and the brightness stage are stored and may be switched on when the power supply is restored. Automatic electronic overload protection and overtemperature switch-off.

**Connection to the Eltako RS485 bus, terminals RSA and RSB.**

**Up to a total of 128 actuators can be added in this way.**

The wireless constant light controller FKR12UD receives its information from one or several wireless sensors FAH or FBH via a wireless antenna module FAM12-12V DC and then controls the output or switches the light on or off. Since incandescent lamps and halogen lamps have a large infrared percentage like daylight, these lamps can only be controlled by measuring the brightness outside the building by a wireless outdoor brightness sensor FAH acting as master. Motion detection takes place inside the room by a FBH acting as slave. Dimmable energy saving lamps and LED require only a FBH inside the room for brightness control and motion detection.

**Operating modes BA are taught-in: 1 = fully automatic ESL (for brightness-dependent and motion-dependent switch-on and switch-off of ESL), 2 = semiautomatic ESL (only for brightness-dependent and motion-dependent switch-off of ESL), 3 = switch-off of ESL is brightness-dependent (only for brightness-dependent switch-off of ESL, the motion sensor inside the FBH is then inactive), 4 = fully automatic incandescent/ halogen lamps, 5 = semiautomatic incandescent/halogen lamps, 0 = fully automatic 230V LED lamps (dimming curve 1), 10 = semiautomatic 230V LED lamps (dimming curve 1), 20 = fully automatic 230V LED lamps (dimming curve 2), 30 = semiautomatic 230V LED lamps (dimming curve 2).**

**With one wireless pushbutton or wireless hand-held transmitter the automatic system can be overloaded to a preset value in order to dim the light for a beamer presentation, for example.**

Several FBHs can be taught-in in a FKR12UD. As long as one of the motion detection sensors detects activity, the necessary lighting remains on and only after all FBHs report no activity for 1 minute does the adjustable time delay RV commence.

Only a FBH in operation mode BA 1, 2 or 3, otherwise a FAH provides constant light control. The FBHs and FAHs can also be taught-in in several FKR12s. This not only allows an increase in the total switching capacity but also the set-up of zones with different brightness settings by setting different basic brightness values GH. Several independent FKR12 systems can be installed simultaneously.

**To teach-in wireless pushbuttons and wireless hand-held transmitters, one rocker is taught-in as direction switches.** Tap the bottom part to switch the light off. Press the top or bottom to dim up or down. This shifts the control automatic towards brighter or darker. A double tap on the bottom part dims down to the taught-in value 'Beamer Presentation'. When the light is switched off and the top part is held down, the light is dimmed up from the lowest brightness level until the rocker is released. Resetting to automatic control is effected either by automatic light switch-off or by double-tapping the top direction switch.

**Function rotary switches**

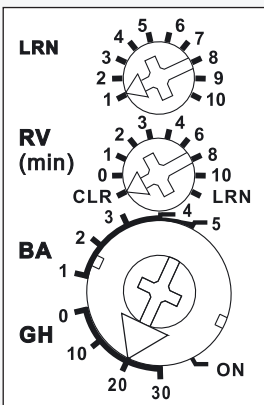

Standard setting ex works.

**Typical connection**

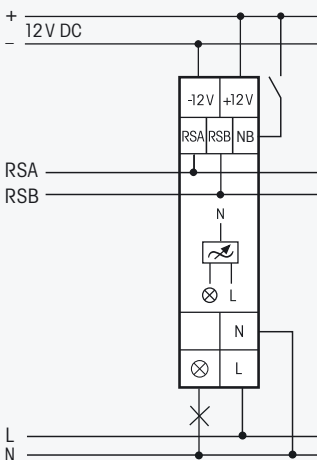

The beamer brightness can additionally be taught-in in a further universal switch. **In addition to the beamer brightness the minimum brightness and the brightness for emergency lighting can be set and stored.** As long as the control input NB is connected to +12V DC, it is dimmed to the set brightness for emergency lighting. All wireless signals are ignored then.

**The upper rotary switch LRN** is required for teach-in and for setting the base brightness. **The middle rotary switch RV** is set after teach-in to the required delay time from 0 to 10 minutes, provided a FBH is available. There is also an additional 1 minute of FBH. The base brightness **GH** dependent on use of the room is set **with the lower rotary switch plus the upper rotary switch** adding the adjusted values. The smallest settable value is 1 (0+1), the largest value is 40 (30+10). The normal setting is approx. at 21. **The LED** below the upper function rotary switch performs during the teach-in process according to the operation manual. It shows control commands by short flickering during operation.

Connection example page 2, technical data page 12. **Teach-in according to the operation manual. Also under [www.eltako.com](http://www.eltako.com).**

**FKR12UD-12V DC**

RS485 bus dimming actuator constant light controller

EAN 4010312300961

**56,50 €/pc.**

**FAM12-12V DC**

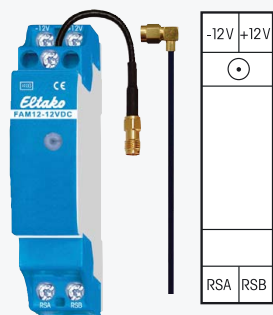

The enclosed small antenna can be replaced with a wireless antenna FA250 or FA200 with magnetic base and cable.

**Wireless antenna module for the Eltako RS485 bus with exchangeable antenna. Only 0.7 watt standby loss. If required, a wireless antenna FA250 or FA200 can be connected.**

Modular device for DIN-EN 60715 TH35 rail mounting.  
1 module = 18mm wide, 58mm deep.

**The wireless antenna module FAM12 receives and tests all signals from wireless transmitters and repeaters within its receiving range. These are transmitted via an RS485 interface to RS485 bus switching actuators connected in series:**

**Up to 128 actuators can be connected to the Eltako RS485 bus (terminals RSA/RSB).**

**The upper LED shows all perceived wireless commands in the receiving range by short flickering.**

If the lines of the RS485 bus are longer than 2m, a terminal resistor of approx. 220 ohms must be connected **to the last actuator** under the terminal RSA/RSB.

<b>FAM12-12V DC</b>	Wireless antenna module	EAN 4010312300879	<b>62,30 €/pc.</b>
---------------------	-------------------------	-------------------	--------------------

**FA250 and FA200**



**Wireless antenna FA250 with magnetic base and 250 cm cable**

The small enclosed wireless antenna of the wireless antenna modules and several wireless transmitter modules are replaceable by this larger antenna to receive and transmit wireless signals to or from metal control cabinets. It is mounted on the magnetic base externally and the 250cm cable is routed inside the cabinet. The best performance is achieved by attaching the magnetic foot on a metal surface. The transmit and receive ranges are almost spherical around this antenna. Antenna height, only 9.6cm. With SMA screw terminal. Extension by 5 metres using wireless antenna extension FAV5 or by 10 metres using FAV10.

**High-performance receive antenna FA200 with magnetic base and 200cm cable**

This antenna has a radial gain of up to 7dBi and therefore has a much greater range than wireless antenna FA250. As a trade-off the receive power along the antenna axis is considerably lower. This must be taken into consideration when positioning the antenna. **It may only be used as a receive antenna.** Antenna height 45 cm. With SMA screw terminal. Extension by 5 metres using wireless antenna extension FAV5 or by 10 metres using FAV10.

<b>FA250</b>	wireless antenna with 250cm cable	EAN 4010312300244	<b>19,90 €/pc.</b>
<b>FA200</b>	High-performance receive antenna with 200cm cable	EAN 4010312303306	<b>64,70 €/pc.</b>
<b>FAV5</b>	wireless antenna extension 5m	EAN 4010312302897	<b>23,90 €/pc.</b>
<b>FAV10</b>	wireless antenna extension 10m	EAN 4010312302903	<b>26,80 €/pc.</b>

**NEW**

**FSNT12-12V/12W**

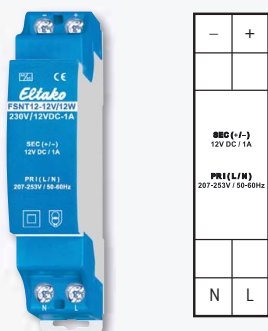

**Rated capacity 12 W. Standby loss 0.2 watt only.**

Modular device for DIN 60715 TH35 rail mounting. 1 module = 18mm wide, 58mm deep. At a load of more than 50% of the rated capacity and always if there are adjacent switching power supply units from 12 W rated capacity and if there are dimmers a ventilation clearance of 1/2 module must be maintained with the spacers DS12 on both sides. Input voltage 230V (-20% up to +10%). Efficiency 83%. Stabilised output voltage  $\pm 1\%$ , low residual ripple. Short-circuit proof. Overload protection and over-temperature switch-off by means of switching off with automatic switching-on after fault clearance (autorecovery function). For redundant operation 2 switching power supply units can be connected in parallel.

April 2012.

<b>FSNT12-12V/12W</b>		EAN 4010312313151	<b>35,50 €/pc.</b>
-----------------------	--	-------------------	--------------------

Recommended retail prices excluding VAT.

**FBH63AP-**

### Wireless motion/brightness sensor for surface mounting, LxWxH = 80x80x39 mm.

In as-delivered state the energy accumulators are empty and must be charged in bright day-light for about 5 hours or connected to a charger for about 10 minutes via the red/black 12V DC connecting cable.

In normal ambient brightness (at least a daily average of 200 Lux), the energy of the integrated solar module is sufficient to power the FBH63. Then the 12V DC connecting cable may be cut off if necessary. The sensor then requires no installation depth behind the mounting plate. It can be screwed or stuck to any flat surface. An adhesive film is supplied.

The power reserve stored in capacitors supplies the power requirement for the night.

**If the ambient brightness is insufficient, power is supplied by the connecting cable from a switching power supply unit FSNT61-12V/6W fitted below in a switch box.**

The complete module can be removed from the frame for screw mounting.

We recommend sheet metal countersink screws 2.9x25 mm, DIN 7982 C, for screw connections. Both with rawl plugs 5x25 mm and with 55 mm switch boxes.

**To teach-in** in an actuator in teach-in mode, hold the supplied blue magnet or any other magnet at hand below the point on the side panel of the sensor marked by ■. This sends a teach-in telegram.

The sensor measures from 0 to 2000 lux and transmits a message to the Eltako wireless network every 100 seconds if the brightness changes by min 10 lux. If the sensor detects motion, it sends a signal twice immediately. The switch-off signal is sent after the off delay which has a fixed setting of 1 minute. If there is no change, a status message is sent every 20 minutes.

When teaching-in in actuators, the switching threshold is defined for switching the light on/off depending on the brightness. Additional variables are also taught-in on the FK12.

If a FBH63 detects motion, then the device is switched on and only when all the FBH63s taught-in in an actuator fail to detect motion for one minute, the actuator return delay starts if this was previously set.

#### Wall mounting

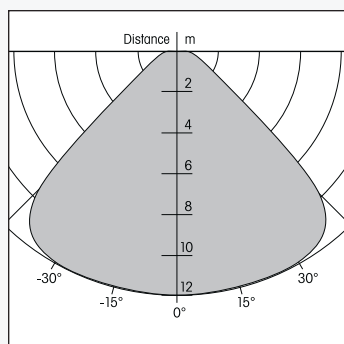

#### Ceiling mounting

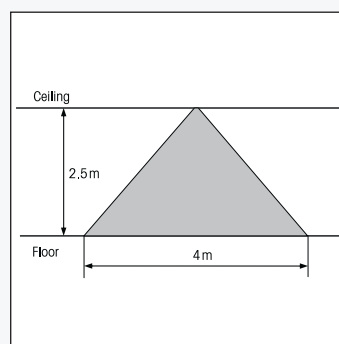
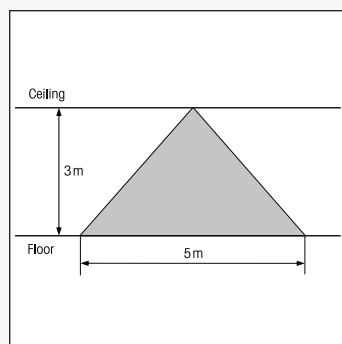

<b>FBH63AP-ws</b>	Motion/brightness sensor white	EAN 4010312303566	<b>129,50 €/pc.</b>
<b>FBH63AP-rw</b>	Motion/brightness sensor pure white	EAN 4010312303573	<b>129,50 €/pc.</b>
<b>FBH63AP-si</b>	Motion/brightness sensor silver grey	EAN 4010312303610	<b>129,50 €/pc.</b>
<b>FBH63AP-an</b>	Motion/brightness sensor anthracite	EAN 4010312303603	<b>129,50 €/pc.</b>
<b>FBH63AP-sz</b>	Motion/brightness sensor black	EAN 4010312303580	<b>129,50 €/pc.</b>
<b>FBH63AP-al</b>	Motion/brightness sensor coated/aluminium paint	EAN 4010312310731	<b>136,70 €/pc.</b>

**FABH63-**



**IP 54**



**Wireless outdoor motion/brightness sensor,  
LxWxH = 80x80x39 mm, protection class IP54.**

In as-delivered state the energy accumulators are empty and must be charged in bright daylight for about 5 hours.

In normal ambient brightness (at least a daily average of 200 Lux), the energy of the integrated solar module is sufficient to power the FABH63.

The power reserve stored in capacitors supplies the power requirement for the night.

The sensor requires no installation depth behind the mounting plate and can be screwed or stuck to any flat surface. An adhesive film is supplied.

We recommend sheet metal countersink screws 2.9x25 mm, DIN 7982 C, for screw connections. Both with rawl plugs 5x25 mm and with 55 mm switch boxes.

**To teach-in** in an actuator in teach-in mode, hold the supplied blue magnet or any other magnet at hand below the point on the side panel of the sensor marked by ■. This sends a teach-in telegram.

The sensor transmits a message to the Eltako wireless network every 100 seconds if the brightness changes by min 10 lux. If the sensor detects motion, it sends a signal twice immediately. The switch-off signal is sent after the off delay which has a fixed setting of 1 minute. If there is no change, a status message is sent every 20 minutes.

When teaching-in in actuators, the switching threshold is defined for switching the light on/off depending on the brightness. Additional variables are also taught-in on the FKR12.

If a FABH63 detects motion, then the device is switched on and only when all the FABH63s taught-in in an actuator fail to detect motion for one minute, the actuator return delay starts if this was previously set.

**Wall mounting**

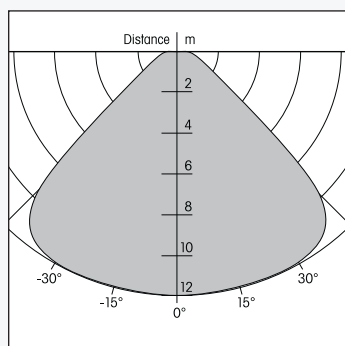

**Ceiling mounting**

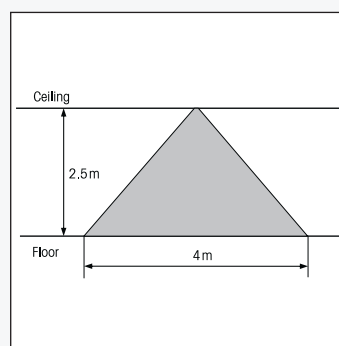
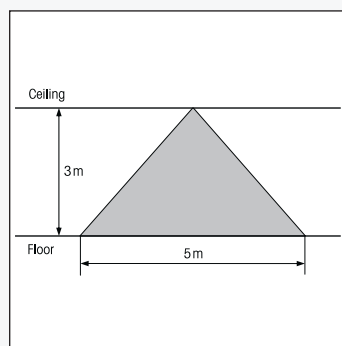

<b>FABH63-rw</b>	Outdoor motion/brightness sensor pure white	EAN 4010312312056	<b>133,70 €/pc.</b>
<b>FABH63-si</b>	Outdoor motion/brightness sensor silver grey	EAN 4010312312094	<b>133,70 €/pc.</b>
<b>FABH63-an</b>	Outdoor motion/brightness sensor anthracite	EAN 4010312312087	<b>133,70 €/pc.</b>
<b>FABH63-sz</b>	Outdoor motion/brightness sensor black	EAN 4010312312063	<b>133,70 €/pc.</b>

Recommended retail prices excluding VAT.

# Wireless Sensor

## Outdoor Brightness Sensor FAH60

8

**FAH60**



**IP 54**



### Wireless outdoor brightness sensor, 60x46 mm, 30 mm deep.

The electronic requires no intrinsic power supply, so there is no standby loss.

The wireless outdoor brightness sensor FAH60 powered by a solar module covers the range from 0 to 30 000 Lux. From approx. 300 Lux, it transmits a wireless telegram to the Eltako wireless network every time there is a brightness change of more than approx. 500 Lux within approx. 10 seconds.

If the brightness does not change, a control signal is sent approx. every 100 seconds.

**New actuators FSR and FSB can cover the range from 0 to approx. 30 Lux using the twilight switch function. A wireless telegram is sent about every 100 seconds within this range.**

Starting in production week 28/2011: **To teach-in** in an actuator in teach-in mode, hold the supplied blue magnet or any other magnet at hand below the point on the side panel of the sensor marked by ■. This sends a teach-in telegram.

### Solar-powered energy accumulator:

Before startup the energy accumulator must be charged.

The charge time is approx. 5 hours at 400 Lux. Keep the cover of the solar cell clean!

The protection class is IP54, the allowable ambient temperature is -20°C to +55°C.

For screw mounting or attachment with adhesive. The scope of supply comprises an adhesive foil.

Shading elements may not cover brightness sensors. Keep the cover of the solar cells clean!

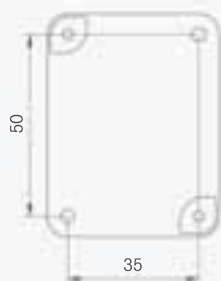
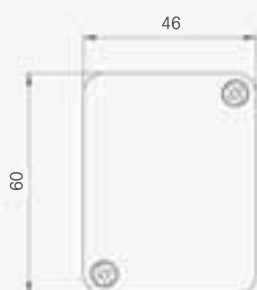

**FAH60**

Wireless outdoor brightness sensor

EAN 4010312305218

**89,90 €/pc.**

Recommended retail prices excluding VAT.



Pages see catalogue  
"Eltako – The Wireless Building"

The shapes and colours of the pushbuttons	1-0
Pushbuttons without battery or wire <a href="#">FT4F</a> , <a href="#">FT55</a> and <a href="#">FT4</a>	
<b>NEW</b> flat pushbuttons <a href="#">FFT55Q</a> and mini pushbuttons <a href="#">FMT55</a>	1-1
Noiseless pushbuttons <a href="#">FT4GF</a> , <a href="#">FT55G</a> and <a href="#">FT4G</a>	1-15
Pushbuttons with sensor key <a href="#">FT2SF</a> , <a href="#">FT55S</a> and <a href="#">FT2S</a>	1-25
Pushbutton lighting <a href="#">FTB</a>	1-32
Accessories: Frames, blind cover, socket outlet and intermediate frames as well as single rockers	1-33
Wireless pushbuttons <a href="#">FT4CH</a> and blind cover <a href="#">BLA-CH</a> , Swiss Design	1-38
Wireless sensors temperature controllers <a href="#">FTR55-CH</a> , <a href="#">FTR55D-CH</a> , energy consumption indicator <a href="#">FEA55D-CH</a> and timer <a href="#">FSU55D-CH</a> , Swiss Design	1-40
Universal remote control <a href="#">UFB</a> , hand-held transmitters <a href="#">FHS</a> and mini hand-held transmitters <a href="#">FMH</a>	1-41
Window/door contact <a href="#">FTK</a>	1-57
Wireless window handles <a href="#">FHF</a> from Hoppe (SecuSignal)	1-58
Wireless sensor hotel key card switches <a href="#">FKF</a> and <b>NEW</b> <a href="#">FKC</a>	1-59
<b>NEW</b> Wireless sensor pull switch <a href="#">FZS</a>	1-61
Compatible design frames from other manufacturers	1-62

## Technical data

Contacts	FKR12/1-10V	FKR12UD-12 V DC
Contact material/contact gap	AgSnO <sub>2</sub> /0.5 mm <sup>b)</sup>	Power MOSFET
Rated switching capacity each contact	600 VA <sup>5)</sup>	–
Incandescent lamp and halogen lamp load <sup>2)</sup> 230V	–	up to 500 W <sup>1) 3) 4)</sup>
Fluorescent lamp load with KVG* shunt-compensated or with EVG*	600 VA <sup>5)</sup>	–
Compact fluorescent lamps with EVG* and energy saving lamps	–	up to 100 W <sup>6)</sup>
Dimmable 230V LED lamps	–	up to 100 W <sup>6)</sup>
Service life at rated load, cos φ = 1 or incandescent lamps 500W at 100/h	> 10 <sup>5</sup>	–
Service life at rated load, cos φ = 0.6 at 100/h	> 4 x 10 <sup>4</sup>	–
Max. operating cycles	10 <sup>3</sup> /h	–
Maximum conductor cross-section (3-fold terminal)	6 mm <sup>2</sup> (4 mm <sup>2</sup> )	6 mm <sup>2</sup> (4 mm <sup>2</sup> )
Two conductors of same cross-section (3-fold terminal)	2.5 mm <sup>2</sup> (1.5 mm <sup>2</sup> )	2.5 mm <sup>2</sup> (1.5 mm <sup>2</sup> )
Screw head	slotted/cross-head, pozidriv	slotted/cross-head, pozidriv
Type of enclosure/terminals	IP50 / IP20	IP50 / IP20
<b>Electronics</b>		
Time on	100%	100%
Max./min. temperature at mounting location	+50°C/-20°C	+50°C/-20°C
Standby loss (active power)	0.9 W	0.3 W

<sup>b)</sup> Bistable relay as relay contact. After installation, wait for short automatic synchronisation before teaching-in the wireless pushbuttons.

<sup>1)</sup> At a load of more than 300W a ventilation clearance of 1/2 module to adjacent devices must be maintained.

<sup>2)</sup> Applies to lamps of max. 150W.

<sup>3)</sup> Per dimmer or capacity enhancer it is only allowed to use max. 2 inductive (wound) transformers of the same type, furthermore no-load operation on the secondary part is not permitted. The dimmer might be destroyed. Therefore do not permit load breaking on the secondary part. Operation in parallel of inductive (wound) and capacitive (electronic) transformers is not permitted!

<sup>4)</sup> **When calculating the load a loss of 20% for inductive (wound) transformers and a loss of 5% for capacitive (electronic) transformers must be considered in addition to the lamp load.**

<sup>5)</sup> Fluorescent lamp or low voltage halogen lamp with electronic ballast units.

<sup>6)</sup> In the settings and operation modes for dimmable energy saving lamps ESL and LED no wound (inductive) transformer must be dimmed.

**If the lines of the RS485 bus are longer than 2m, a terminal resistor of approx. 220 ohms must be connected to the last actuator under the terminal RSA/RSB.**

\* EVG = electronic ballast units; KVG = conventional ballast units

Eltako Wireless is based on the EnOcean wireless standard for 868 MHz, frequency 868.3 MHz, data rate 125 kbps, modulation mode ASK, max. transmit power 7 dBm (< 10 mW).

Compliance with: EN 61 000-6-3, EN 61000-6-1 and EN 60 669

## Operating distances between sensors and actuators

Compared with hard-wired systems, EnOcean wireless systems are highly flexible and simple to install. The following instructions simplify installation. You will find detailed instructions on wireless network planning in the 12-page booklet "EnOcean Wireless Systems – Range planning Guide" that you can download from [www.enocean.com](http://www.enocean.com).

### 1. Wireless signal range

Wireless signals are electromagnetic waves. The field strength at the receiver decreases the further the distance away from the transmitter. **The wireless range is therefore limited. Obstacles standing in the radio field also shorten range compared with line-of-sight links:**

Obstacle	Reduced range
Wood, plaster, glass uncoated, with no metal	0 - 10 %
Brick, particle board	5 - 35 %
Concrete with iron reinforcement bars	10 - 90 %
Metal, aluminium cladding	<i>see 2.</i>

The geometric shape of a room determines the radio range since propagation is not in the form of a beam but requires a certain volume of space (the radio beam from the transmitter and receiver ellipsoidal at their points of focus). Narrow corridors with solid walls are bad for propagation.

External antennas typically have better radio characteristics than flush-mounted receivers installed in walls. The type of fitted for the antennas and the spacing from ceilings, floors and walls all play a role.

People and obstacles in a room may reduce range.

It is therefore essential to integrate some reserve when performing range planning to ensure the reliable functioning of the wireless system even in poor conditions.

**A sturdy, reliable installation in a building is achieved by integrating sufficient range reserves.**

**Recommendations from everyday practice:**

Range	Conditions
> 30 m	Under excellent conditions: Large free room, optimum antenna design and good antenna position.
> 20 m (planning safety)	If there are furniture and persons in the room, through up to 5 dry plasterboard walls or 2 brick/aerated concrete walls: For transmitters and receivers with good antenna design and good antenna position.
> 10 m (planning safety)	If there are furniture and persons in the room, through up to 5 plasterboard drywalls or 2 brick/aerated concrete walls: For receivers fitted in wall or in ceiling. Or small receiver with internal antenna. Or together with switch/wire antenna on/near metal. Or a narrow corridor.
Dependent on reinforcement and antenna design	Vertical through 1-2 ceilings

### 2. Partitioning

So-called radio shadows form behind metal surfaces, e.g. behind metal partition walls and metal ceilings, behind metal foils of heat insulation and solid reinforcement in concrete walls. Single thin metal strips have very little influence, for example the profile sections in a plasterboard drywall.

It has been observed that radio communications also works with **metal room dividers**. This occurs by reflections: metal and concrete walls reflect radio waves and they travel to neighbouring corridors or rooms through openings, e.g. in a wooden door or a glass partition. The range may be strongly reduced depending on the location. An additional repeater at a suitable location can easily offer alternative radio paths.

**Important conditions that reduce radio range:**

- Metal partition walls or hollow walls filled with insulation wool backed by metal foil
- Suspended ceilings with panels made of metal or carbon fibre
- Steel furniture or glass with metal coating
- Fitting the pushbutton on a metal wall (typical range loss: 30%)
- Use of metal pushbutton frames (typical range loss: 30%)

Firewalls, staircases and building services areas should be regarded as partitions.

**A partition can be avoided by repositioning the transmitter/receiver antenna out of the radio shadow or by using a repeater.**

## Operating distances between sensors and actuators

### 3. Penetration angle

The angle at which the transmitted signal impinges on the wall plays a special role. Signals should penetrate masonry as vertically as possible. Wall niches must be avoided.

### 4. Antenna installation

The receive antenna or a **receiver with an integrated antenna** should not be installed on the same side of the wall as the transmitter. It is better to install the antenna on adjacent or opposite walls. The antennas should be spaced from the room corner at a distance of >10cm as far as possible.

The ideal installation location for the receive antenna is a central position in the room.

A "**magnet foot antenna**" (e.g. Eltako FA200 or FA250) must adhere on a metallic surface that is as large as possible in order to create a sufficient opposite pole. For example, the simplest installation can be on a ventilation pipe.

### 5. Spacings between receiver and other interference sources

The spacing between the receiver and other transmitters (e.g. GSM/DECT/Wireless LAN) and high-frequency interference sources (computer, audio and video systems) should be >50cm.

Eltako transmitters, on the other hand, can be installed without any problem next to other transmitters and interference sources.

### 6. Use of repeaters

In case of problems with reception quality, it may be helpful to use a wireless repeater. The Eltako Repeater FRP61 (see page Z-0) requires no configuration, only a mains connection. It receives the wireless signal and passes it on. This almost doubles the range. Eltako repeaters are switchable to 2-level function and allow more than two repeaters to be cascaded.

### 7. Field strength measuring instrument

The field strength measuring instrument EPM100 (see page Z-3) helps to find the best position for transmitter and receiver. Moreover, it can be used to test link interferences in installed devices and even identify an interfering transmitter.

### 8. Installation in residential buildings

Here there is no real necessity to overcome large radio links. If necessary, a central wireless repeater can be installed to amplify the signal.

### 9. Installation in industrial buildings

To cover large premises, a wireless gateway is typically used as an automation bus (TCP/IP, EIB/KNX, LON, etc.). Planning with a range radius of 10-12m offers sufficient security, even if there are the usual changes to the environmental conditions later.