

## 4-fold impulse switch ES12Z-4x8..230V UC also for central control and group control



With 4 independent impulse switch functions, 1 NO contact each potential free 16A/250V AC, incandescent lamp load up to 2000W.

Standby loss 0.5 watt only.

Modular devices for DIN-EN 50 022 rail mounting. 2 modules = 36mm wide, 58mm deep.

State-of-the-art hybrid technology combines advantages of nonwearing electronic control with high capacity of special relays.

Local universal control voltage 8 to 230V UC. In addition universal control inputs central ON and central OFF for 8 to 230V UC, electrically isolated from the local inputs.

With additional group control inputs ON and OFF for 8..230V UC. Same potential like the local control inputs. Groups of these impulse switches can be controlled separately using the group control inputs.

Supply voltage like the local control voltage. Very low switching noise.

**By using a bistable relay causing coil power loss and heating is avoided even in the on mode.**

The switched consumer may not be connected to the mains before the automatic synchronisation after installation has terminated.

Central commands always have priority, local control inputs are blocked as long as central commands are activated.

In case of a power failure the system is disconnected in a defined mode.

With check back signal ER (= +B1) for control of a relay with the supply voltage of the ES12Z-4x as control voltage and up to 2 Watt control power demand.

Glow lamp current starting at 110V control voltage up to 30mA.

### Typical connection

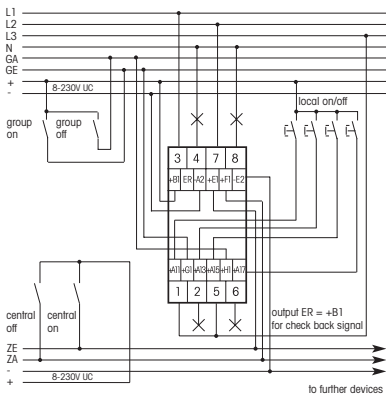

### Technical data

Central control voltage + local	8..230V UC
Rated switching capacity	16A/250V AC
Incandescent lamp load and halogen lamp load <sup>1)</sup>	2000W 230V
Fluorescent lamp load with KVG in lead-lag circuit or non compensated	1000VA
Fluorescent lamp load with KVG shunt-compensated or with EVG	500VA
Compact fluorescent lamp with EVG and energy saving lamps	1 on ≤ 70A/10ms <sup>2)</sup>
Standby loss (activ power)	0.5W

<sup>1)</sup> For lamps with 150W max.

<sup>2)</sup> For electronic ballast gears a 40fold inrush current has to be calculated. For steady loads of 1200W or 600W use the current-limiting relay SBR12 or SBR61.



The strain relief clamps of the terminals must be closed, that means the screws must be tightened for testing the function of the device. The terminals are open ex works.

### Warning!

**Only a trained electrician may install this equipment, otherwise there is a risk of fire or electric shock.w**