

Single-phase energy meter CE

WSZ12E-65A without approval

Maximum current 65A. Standby loss 0.3 watt only.

Modular device for DIN-EN 60715 TH35 rail mounting.

2 modules = 35mm wide and 58mm deep.

Accuracy class B (1%).

With SO interface.

It measures active energy by means of the current between input and output. The internal powerconsumption of 0.3 watt active power is neither metered nor indicated.

1 phase conductor with a max. current up to 65A can be connected.

The inrush current is 40mA.

The meter can be read anytime without power supply.

A red LED indicates a power consumption or a possible wrong connection.

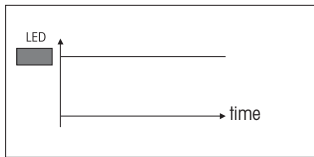

Energy meter connected, no power consumption

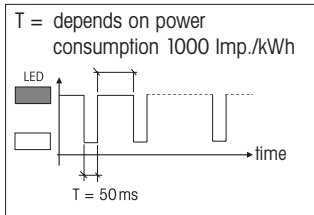

Energy meter correctly connected, with power consumption

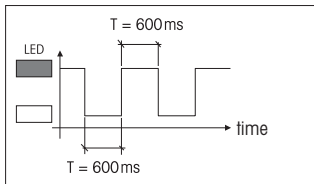

Energy meter wrongly connected, (↑L-↓L vice-versa connected), with or without power consumption

Typical connection

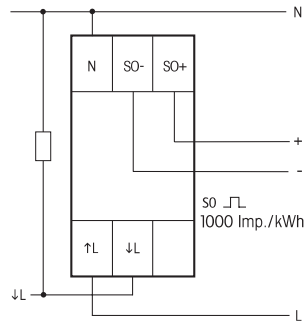

Technical Data

Rated voltage	230V, 50 Hz,
Extended range	20%/+15%

Reference current I_{ref} (Limiting current I_{max})	10 (65) A
--	-----------

Internal consumption	0,3 W
Active power	

Display active power	drum type register with 6 digits for kWh and 1 decimal digit
----------------------	--

Accuracy class $\pm 1\%$	B
--------------------------	---

Inrush current according to accuracy class B	40 mA
---	-------

Operating temperature	-10/+55°C
-----------------------	-----------

Interface	Pulse interface SO according to DIN EN 62053-31, potential free by opto-coupler, max. 30V DC/20 mA and min. 5V DC, impedance 100 ohms, pulse length 50 ms, 1000 Imp./kWh
-----------	---

Terminal cover sealable	With sealing cap PK36. For the current path 1 sealing cap is required
----------------------------	---

Protection degree	IP50 for mounting in distribution cabins with protection class IP51
-------------------	---

Maximum conductor cross section	N and L terminals 16 mm ² SO terminals 6 mm ²
------------------------------------	--

Warning!

Only a trained electrician may install this equipment, otherwise there is a risk of fire or electric shock.