

1-10V control dimmer switch

SDS61/1-10V for electronic ballast units

1 NO contact not potential free 600VA and 1-10V control output 40mA. Only 1 watt standby loss. With adjustable dimming speed. With switching operation for children's rooms and snooze function. With pushbutton or switch activation.

Built-in device for installation. 45mm long, 55mm wide, 33mm deep.

Zero passage switching with soft ON and soft OFF to protect lamps.

Switching voltage and control voltage 230V.

State-of-the-art hybrid technology combines advantages of nonwearing electronic control with high switching capacity of special relays.

The load is switched on and off by a bistable relay at output EVG (electronic ballast units). Switching capacity for fluorescent lamps or LV halogen lamps with electronic ballast units 600VA.

By using a bistable relay coil power loss and heating is avoided even in the on mode.

After installation, wait for short automatic synchronisation before the switched consumer is connected to the mains.

Short-time control commands switch on/off, permanent control varies the brightness up to the maximum level. An interruption of control changes the direction of dimming.

The brightness level is stored after switching off.

In case of a power failure the switching position and the brightness level are stored. If applicable the dimmer will be switched on at the stored brightness level after the supply voltage is recovered.

Function rotary switch

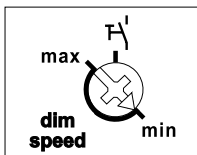

The dimming speed is adjustable using the dimming speed rotary switch (only for pushbutton activation).

If light switches cannot be replaced by light pushbuttons, the rotary switch can be set to the switch symbol at the right stop:

When the closed switch is briefly opened, the light is dimmed until the switch is briefly opened again. The dimming direction is changed automatically at each of the two vertices. In addition the direction can be changed by opening the switch briefly twice.

Switching operation for children's rooms

(only for pushbutton activation): If the light is switched on by holding down the pushbutton, it starts at the lowest brightness level after approx. 1 second and dims up slowly as long as the pushbutton is held down without modifying the last stored brightness level.

Snooze function (only for pushbutton activation):

With a double impulse the lighting is dimmed down from the current dimming position to the minimum brightness level and switched off. The current dimming position as well as the adjustable minimum brightness level determine the dimming time (max. = 60 minutes) which can be reduced as required. It can be switched off at any time by short-time control commands during the lighting is dimmed down. Holding down the pushbutton during the dimming down process dims up and stops the snooze function.

Function rotary switches

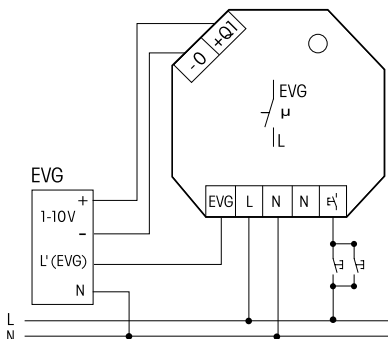

Important Note!

Only skilled electricians may install this electrical equipment otherwise there is the risk of fire or electric shock.