

Digitally adjustable motor dimmer MOD12D-UC



! Note: Select English language !*

Power MOSFET up to 300W. Standby loss 0.3 watt only. Minimal speed, maximum speed and dimming speed are adjustable.

Modular device for DIN EN 60715 TH35 rail mounting.

1 module = 18mm wide, 58mm deep.

Motor dimmer with phase control for L loads up to 300W, depending on ventilation conditions. Only 1 motor may be connected.

Universal control voltage 8 to 230V UC and additionally the universal voltage control inputs 8 to 230V UC central ON and central OFF. The control inputs are electrically isolated from the supply voltage and switching voltage.

Switching in zero crossing and switch-on at increased speed.

If there is a power failure, the switch position and the speed level are saved. The device can be switched on when the power supply is restored.

Automatic electronic overload protection and over-temperature switch-off.

Enter the 6 functions and times using the MODE and SET keys as described in the operator manual. The functions and times are indicated in the LC display. Other features include language selection and keylock.

The total switch-on time is added and indicated in the bottom line of the display. It can be reset to zero.

The top line shows the parameters during the setting procedure and the active function in service. The left arrow indicates the switch position 'ON' and the right arrow shows the keylock function when applied. During the setting procedure, the middle line shows the parameters set. In service, the middle line indicates the speed between 10 and 99 for the MOD and DSD functions or the remaining time in minutes for the Udo and ODT functions.

MOD = Motor dimmer with settings for dimming speed DSP, minimum speed MI%, maximum speed MA%, memory function MEM+ and selection of the central control inputs ON and/or OFF when activated or deactivated. Short commands switch on/off, permanent activation changes speed.

An interruption in activation changes the dimming direction.

DSD = Motor dimmer with activation with two direction buttons for dimming direction. Setting the dimming speed DSP, minimum speed MI%, maximum speed MA% and memory function MEM+. When activation takes place via +E1, a short command switches on. Permanent activation dims up to maximum speed. A double-click immediately dims to maximum speed. When activation takes place via +F1, a short command switches off. Permanent activation dims down to minimum speed. No central control function.

Udo = Motor dimmer as for MOD function with manual on/off. In addition, a time delay time TIM can be set from 1 to 99 minutes. When the time delay expires, the device switches off. Central ON has priority over Central OFF.

ODT = Motor dimmer with run-on switch function with adjustable speed SP%, response lag AV adjustable from 1 to 99 minutes and time delay RV adjustable from 1 to 99 minutes. When the control voltage is applied, the device switches on after the AV time expires. When the control voltage cuts off, the RV time begins. When the RV time expires, the device switches off. No central control function.

ON = Permanent ON at maximum speed,
OFF = Permanent OFF.

Press MODE and SET briefly and simultaneously to activate the keylock. Then press SET to confirm the flashing LCK. Press MODE and SET simultaneously for 2 seconds to deactivate keylock. Then press SET to confirm the flashing UNL.

Typical connection MOD

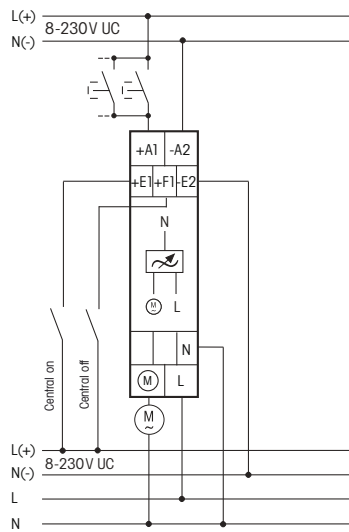

Typical connection DSD

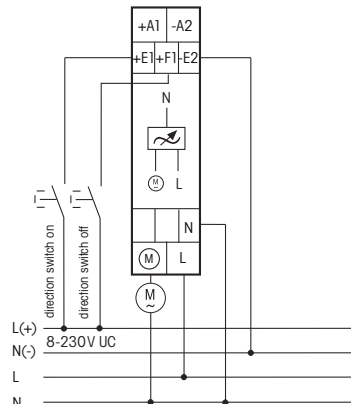

Technical data

1 Motor inductive	up to 300W
Standby loss (activ power)	0.3W

How to operate the MOD12D-UC with display

* After you switch on the power supply (or the power supply is switched on after a power failure), the top line of the display indicates the **language setting**. It flashes for 10 seconds: D = German, GB = English, F = French, IT = Italian and ES = Spanish. During this time, press SET to make changes, press MODE to save and then switch over to normal display.

Press MODE to activate the setting mode. The function abbreviation of the current function starts to flash in the top line of the display. Each time you press SET, you move to the next flashing function.

This is the function sequence:

MOD, DSD, Udo, ODT, ON and OFF.

Press MODE on the requested function to end the flashing function.

Then set by pressing MODE+SET.

Retain and only change a function:

Press MODE twice.

When you select a function by pressing MODE, the first submenu option (Parameters) of the corresponding function flashes. Press SET to change the function.

When you press SET briefly, the parameter increments step by step. When you press the button for longer, the parameter increments faster through to the maximum value. The display then restarts from the minimum parameter value. When you press the button for longer after a rapid forward runup, the display reverses and the digits decrement to the minimum parameter value. Press MODE again to change to the next parameter of the activated function.

After the last parameter, exit the setting mode by pressing MODE. The device is then ready to operate with the corresponding function.

The following setting parameters are available for the individual functions:

MOD:

DSP Dimming speed from 1 (slow) to 9 (fast)

MI% Minimum speed from 10 to 50

MA% Maximum speed from 50 to 99 (full speed) (MA% - MI% >= 20)

MEM Memory function (+ behind MEM with memory, otherwise without memory function)

Cla Select central control inputs

boCl Both central inputs activated

noCl No central input activated

Coff Only Central OFF activated

Con Only Central ON activated

A1-A2: Short commands switch on/off, permanent activation changes speed.

An interruption in activation changes the dimming direction.

DSD:

DSP same as MOD

MI% same as MOD

MA% same as MOD

MEM same as MOD

+E1: Short commands switch on, permanent activation dims up to maximum speed.

+E1: Double-click dims to maximum speed.

+F1: Short commands switch off, permanent activation dims down to minimum speed.

Udo:

DSP same as MOD

MI% same as MOD

MA% same as MOD

MEM same as MOD

TIM Time delay time from 1 to 99min (up to 10min in steps of 0.5min, then in steps of 1 min)

ODT:

SP% Speed from 10 (minimum speed) to 99 (maximum speed)

AV Response lag from 0 to 99min (up to 1 min in steps of 1s, then in steps of 1 min)

RV Time delay from 0 to 99min (up to 1 min in steps of 1s, then in steps of 1 min)

When the control voltage is applied, the device switches on after the AV time expires. When the control voltage cuts off, the RV time begins. When the RV time expires, the device switches off.

The progressive switch-on time is continuously indicated. First in hours (h), then in months (m) with 1 digit after the decimal point.

Lock and unlock

If the automatic function is active (no element is flashing), the setting can be locked against unintentional adjustment and then unlocked. As long as it is locked, an arrow at the top right of the display points to a lock icon on the front panel.

Lock: Press MODE and SET simultaneously and briefly. **LCK** flashes. Lock by pressing SET.

Unlock: Press MODE and SET simultaneously for 2 seconds. **UNL** flashes.

Unlock by pressing SET.



The strain relief clamps of the terminals must be closed, that means the screws must be tightened for testing the function of the device. The terminals are open ex works.

Important Note!

Only skilled electricians may install this electrical equipment otherwise there is the risk of fire or electric shock.