

Digital settable sensor relay

LRW12D-UC

Light-twilight rain wind sensor relay,
4 OptoMOS semiconductor outputs
50mA/8...230V UC.

Standby loss 0.05-0.5 watt only.

Modular device for DIN 60715 TH35 rail
mounting.

1 module = 18mm wide, 58mm deep.

Supply voltage 8 to 230V UC.

The sensor relay LRW12D evaluates the signals from the light sensor LS, the rain sensor RS and the wind sensor WS and sends appropriate control signals to the downstream EGS12Z or EGS12Z2 actuators depending on the setting via the display on the front panel.

The OptoMOS semiconductor outputs switch the voltage applied to the universal voltage input terminal +B1.

A light sensor LS, rain sensor RS and wind sensor WS can be connected to a sensor relay LRW12D. However, only one per sensor. However, at a wind sensor WS several LRW12D can be connected for controlling different wind speeds. Then the LRW12D must be connected to the same potential +B1/A2.

When the supply voltage UC (8-253V AC or 10-230V DC) is applied to B1/A2, the LRW12D can be set:

First **segment 1** indicates 'LS' or 'DSR' and **segment 3** may then indicate closed outputs 2, 3, 4 or 5. 'LS' indicates that the LRW12D is set as light sensor relay (factory setting) and 'DSR' shows that it is set as light-twilight relay. In both settings, the signals of connected rain and wind sensors may also be evaluated. A light sensor need not be connected.

Segment 2 indicates alternating events: s = brightness overshoot (sun), m = brightness undershoot (moon). If a release delay runs, the affected output flashes in segment 3.

Select the function for which values require changes by pressing the countersunk buttons **MODE** and **SET**: Press **MODE** and select the flashing function by pressing **MODE**. Alternatively browse through the available functions by pressing **SET** and then select the required function by pressing **MODE**.

Functions

LS = light sensor, WS = wind sensor, RS = rain sensor, DSR = light-twilight relay, TST = test and OFF = switch all functions on/off. When the required function flashes,

confirm it by pressing **MODE**. Then the first of the adjustable subfunctions flashes.

Subfunctions at LS = light sensor

LSM indicates the current light sensor measured value in klux in segment 3, provided a light sensor LS is connected. No input is possible.

LSS indicates the brightness in klux; this setting immediately triggers the sun signal as a 2 second impulse at output 2 in the event of an overshoot. Press **SET** to adjust the value between 3 klux and 60 klux and confirm by pressing **MODE**. Hysteresis then decrements automatically by 2 steps lower.

LSD indicates the brightness in klux; this setting triggers the light/twilight signal as a 2-second impulse at output 3 in the event of an undershoot dependent on the following set delay time RV.

Press **SET** to adjust the value between 1 klux and 40 klux and confirm by pressing **MODE**.

RV indicates the delay time by which the light/twilight signal is tripped delayed. Press **SET** to adjust the value between 0 and 60 minutes and confirm by pressing **MODE**.

Subfunctions at WS = wind sensor

WSM indicates the current wind sensor measured value in m/s in segment 2, provided a wind sensor WS is connected. No input is possible.

WSS indicates the settable wind speed from 2 to 20 m/s; its setting immediately triggers the wind signal by closing output 5 in the event of an undershoot. If the wind speed again drops below the set value, the output is released after the following set delay time RV. If the sun signal is applied at this moment, a 2-second impulse is triggered at output 2.

RV indicates the delay time by which the wind signal is terminated delayed. Press **SET** to adjust the value between 0 and 60 minutes and confirm by pressing **MODE**.

Subfunctions at RS = rain sensor

ON or **OFF** indicates whether the rain sensor evaluation is switched on or off by the rain sensor RS.

Press **SET** to switch over as required and press **MODE** to confirm. When it is switched on, output 4 is closed when it rains. After drying the sensor surface assisted by the heater, output 4 opens on expiry of the following adjustable delay time RV. If the sun signal is applied at this moment, a 2-second impulse is triggered at output 2.

RV indicates the delay time by which the opening of output 4 is delayed at the end of rain detection.

Press **SET** to adjust the value between 0 and 60 minutes and confirm by pressing **MODE**.

Subfunctions at DSR = light/twilight sensor relay

DSD indicates the brightness in klux which closes output 3 immediately in the event of an undershoot. Press **SET** to adjust the value between 20 lux (0.020 klux) and 800 lux (0.800 klux) and confirm by pressing **MODE**. Hysteresis then increments automatically by 2 steps higher.

DSS indicates the brightness in klux which opens output 3 according to the following adjustable delay time RV in the event of an overshoot. Press **SET** to adjust the value between 160 lux (0.160 klux) and 2000 lux (2.000 klux) and confirm by pressing **MODE**. Hysteresis then decrements automatically 2 steps lower.

RV indicates the delay time by which output 3 opens delayed in the event of a brightness overshoot. Press **SET** to adjust the value between 0 and 60 minutes and confirm by pressing **MODE**.

In the **TST** function and after you confirm by pressing **MODE**, the OptoMOS outputs 2, 3, 4 and 5 can be closed in succession to test using **SET**. The output closed in each case is indicated in segment 3.

In the **OFF** function, the LRW12D can be switched on or off. After you confirm the flashing **OFF** by pressing **MODE**, **OFF** is indicated and all functions are switched off. Switch on by pressing **MODE** and **SET** and confirm a flashing **ON** by pressing **MODE**.

Lock settings against unintentional readjustment by briefly pressing **MODE** and **SET** simultaneously. When you confirm a flashing display **LCK** by pressing **SET**, you lock the keys and this is indicated by an arrow in segment 1 pointing in the direction of the pressed lock symbol.

Unlock by pressing **MODE** and **SET** simultaneously for 2 seconds. Confirm the flashing display **UNL** by pressing **SET** to unlock. A changed setting only takes effect when the display in segment 1 no longer flashes after you press **MODE** (if necessary several times). 20 seconds after you last press a key, the display returns to the starting display and an unconfirmed change is lost.

Changing light compensation: Constant changes between sun and rain clouds would result in sensitive closing and opening of the shade elements. This is prevented by a changing light compensation function.

Sensor function and open circuit monitoring: If the signal from the light sensor or the wind sensor is missing for 24 hours, then an alarm is triggered: The display indicates 'FLS' or 'FWS'. Failure of the wind sensor results in a 2-seconds pulse at output 5 in order to protect

any awnings or windows which may be connected here. This pulse is repeated every hour. Rain sensor failure or a line break causes output 4 to close. The display indicates 'FRS' 36 hours later.

If several faults occur simultaneously, they are each displayed for one second in succession. When signals are detected again, each alarm stops automatically.

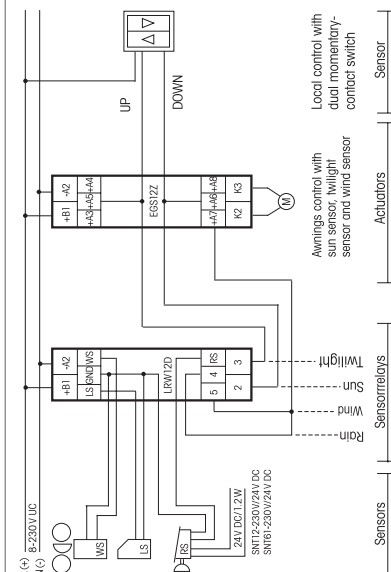
Typical connection

Technical data

Supply voltage	8...230V UC
OptoMOS	50mA/8...230V UC
Max./min. temperature at mounting location	+50°C/-20°C
Standby loss (active power) at 12/24/230V	0.05/0.1/0.5W



The strain relief clamps of the terminals must be closed, that means the screws must be tightened for testing the function of the device. The terminals are open ex works.

Warning!

Only a trained electrician may install this equipment, otherwise there is a risk of fire or electric shock.